

ioLogik E4200

Modular Active Ethernet I/O adaptor



- > Supports up to 16 I/O modules
- > Dual Ethernet LANs and one RS-232 port
- > Front-end intelligence that supports 80 Click&Go rules
- > Unicode Active Messaging with real-time stamp, including SMS, SNMP Trap with I/O status, TCP, email
- > Built-in web console
- > PC utility: Auto detection of installed modules
- > Windows/WinCE VB/VC.NET and Linux C APIs

The certification logos shown here apply to some or all of the products in this section. For details, see "Regulatory Approvals" under "Specifications" below.



Introduction

The ioLogik E4200 is suitable for remote monitoring and alarm systems, such as are used for water treatment systems, water supply systems, wastewater treatment systems, and power monitoring systems. These kinds of applications need more I/O points and a

variety of I/O types, including temperature sensors, gas detectors, and water quality detectors, all of which can benefit from the versatile mixture of I/O features supported by the ioLogik E4200.

Specifications

LAN

Ethernet: 2 x 10/100 Mbps (2 MACs, 2 IPs, RJ45 connectors)

Protection: 1.5 KV magnetic isolation

Protocols: Modbus/TCP, TCP/IP, UDP, DHCP, Bootp, SNMP, SNMP Trap, HTTP, SNTp

Serial Communication

Interface: 1 x RS-232/485 (9-pin D-Sub, male)

Parameters: N, 8, 1

Baudrate: 115,200 bps

Power Requirements

Power Input: 24 VDC nominal, 12 to 36 VDC

Power Consumption: 60 mA typical @ 24 VDC

Current for I/O Modules: Max. 1.5A @ 5 VDC

Field Power

Rated Voltage: 11 to 28.8 VDC, 24 VDC typical

Current in Field Power Contact: Max. 10 A

Isolation

System Power to I/O Driver: Optical isolation

Physical Characteristics

Dimensions: 45 x 99 x 70 mm (1.65 x 3.9 x 2.75 in)

Weight: 180 g

Environmental Limits

Operating Temperature: -10 to 60°C (14 to 140°F)

Storage Temperature: -40 to 85°C (-40 to 185°F)

Ambient Relative Humidity: 5 to 95% (non-condensing)

Regulatory Approvals

EMI: FCC part 15, CISPR (EN55022) Class A

EMS:

IEC 61000-4-2 (ESD), level 2/3

IEC 61000-4-3 (RS), level 2

IEC 61000-4-4 (EFT), level 2

IEC 61000-4-5 (Surge), level 3

IEC 61000-4-6 (CS), level 2

IEC 61000-4-8 (PM), level 1

IEC 61000-4-11 (DIP)

IEC 61000-6-2 (ESD), level 2/3

IEC 61000-6-4 (EFT), level 2

Safety: UL 508

Shock: IEC 60068-2-27

Freefall: IEC 60068-2-32

Vibration: IEC 60068-2-6

Note: Please check Moxa's website for the most up-to-date certification status.

Warranty

Warranty Period: 2 years

Details: See www.moxa.com/warranty

Dimensions (unit = mm)

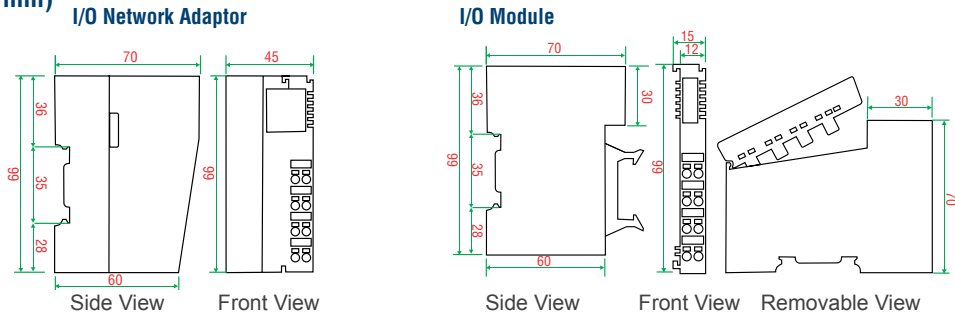

: Ordering Information

Step 1: Select a network adaptor module

ioLogik E4200

Step 2: Select I/O modules

M-1000/2000/3000/4000/6000 Series

Step 3: Select power modules

**Power Modules
M-7001/7002/7804/7805**

Available Models

ioLogik E4200: Active Ethernet network adaptor

Note: The ioLogik E4200 Active Ethernet network adaptor can be expanded by adding up to 16 I/O modules. See pages 5-33 to 5-41 to select the M-series modules for your application.

Modular Remote I/O Selection Guide

I/O Modules



		DC-Digital Inputs				AC-Digital Inputs	
Specs	Model	M-1800	M-1801	M-1600	M-1601	M-1450	M-1451
	Channels	8	8	16	16	4	4
	Sink/Source	Sink	Source	Sink	Source	---	---
	Connector	RTB	RTB	20-pin	20-pin	RTB	RTB
	Voltage	24 VDC	24 VDC	24 VDC	24 VDC	110 VAC	220 VAC
	Isolation	Optical isolation					



		Digital Outputs				
Specs	Model	M-2800	M-2801	M-2600	M-2601	M-2450
	Channels	8	8	16	16	4
	Sink/Source	Sink	Source	Sink	Source	Relay
	Connector	RTB	RTB	20-pin	20-pin	RTB
	Voltage	24 VDC	24 VDC	24 VDC	24 VDC	24 VDC
	Current	0.5 A	0.5 A	0.3 A	0.3 A	0.5 A
	Isolation	Optical isolation				



		Analog Inputs			
Specs	Model	M-3802	M-3810	M-6200	M-6201
	Channels	8	8	2	2
	Current	4 to 20 mA	---	---	---
	Voltage	---	0 to 10V	---	---
	Connector	RTB	RTB	RTB	RTB
	Resolution	12-bit	12-bit	---	---
	Isolation	Optical isolation			
	Sensor Input	---	---	RTD(ohm)	Thermo-couple (mV)



		Analog Outputs	
Specs	Model	M-4402	M-4410
	Channels	4	4
	Current	4 to 20 mA	---
	Voltage	---	0 to 10 V
	Connector	RTB	RTB
	Resolution	12-bit	12-bit
	Isolation	Optical isolation	

Power Modules

		Power Modules			
Specs	Model	M-7001	M-7002	M-7804	M-7805
	Channels	0	0	8	8
	Voltage	24 VDC	DC: 5, 24, 48 VDC AC: 110/220 VAC	0 VDC	24 VDC
	Purpose	System Power	Field Power	Field Power	Field Power



Digital Input Modules

8-channel 24 VDC digital input modules

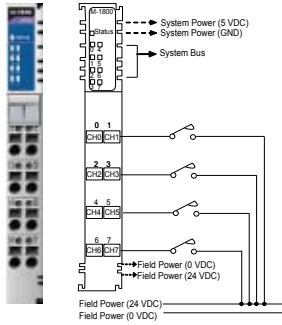

M-1800: 8 digital inputs, sink, 24 VDC

Inputs per Module: 8 channels, sink type
On-state Voltage: 24 VDC nominal, min. 11 VDC to max. 28.8 VDC
Min. Off-state Voltage: Max. 5 VDC
On-state Current: Max. 6 mA/point @ 28.8 VDC
Input Impedance: Typ. 5.1K ohms
Filtering Time: Typ. 1.5 ms
Common Type: External common
Power Consumption: Max. 35 mA @ 5 VDC

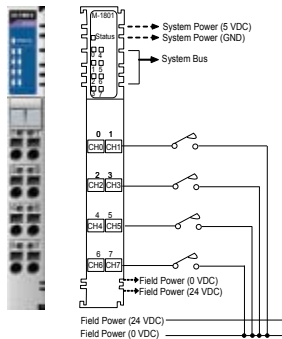

M-1801: 8 digital inputs, source, 24 VDC

Inputs per Module: 8 channels, source type
On-state Voltage: 24 VDC nominal, min. 11 VDC to max. 28.8 VDC
Min. Off-state Voltage: Max. 5 VDC
On-state Current: Max. 6 mA/point @ 28.8 VDC
Input Impedance: Typ. 5.1K ohms
Filtering Time: Typ. 1.5 ms
Common Type: External common
Power Consumption: Max. 35 mA @ 5 VDC



16-channel 24 VDC digital input modules

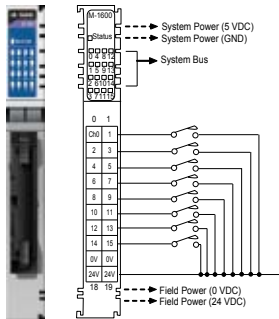

M-1600: 16 digital inputs, sink, 24 VDC

Inputs per Module: 16 channels, sink type
On-state Voltage: 24 VDC nominal, min. 11 VDC to max. 28.8 VDC
Min. Off-state Voltage: Max. 5 VDC
On-state Current: Max. 6 mA/point @ 28.8 VDC
Input Impedance: Typ. 5.1K ohms
Filtering Time: Typ. 1.5 ms
Common Type: 16 channels for 2 COMs
Power Consumption: Max. 40 mA @ 5 VDC



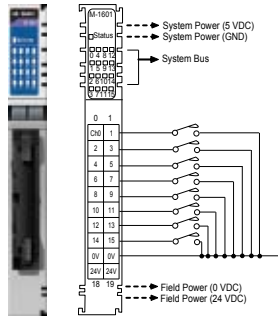

M-1601: 16 digital inputs, source, 24 VDC

Inputs per Module: 16 channels, source type
On-state Voltage: 24 VDC nominal, min. 11 VDC to max. 28.8 VDC
Min. Off-state Voltage: Max. 5 VDC
On-state Current: Max. 6 mA/point @ 28.8 VDC
Input Impedance: Typ. 5.1K ohms
Filtering Time: Typ. 1.5 ms
Common Type: 16 channels for 2 COMs
Power Consumption: Max. 40 mA @ 5 VDC



4-channel AC digital input modules

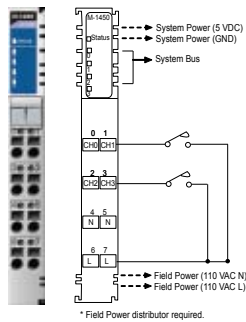

M-1450: 4 digital inputs, 110 VAC

Inputs per Module: 4 channels
On-state Voltage: 120 VAC nominal, min. 85 VAC to max. 132 VAC
Min. Off-state Voltage: Max. 45 VAC
On-state Current: Max. 8 mA/point @ 132 VAC
Input Impedance: Typ. 11K ohms
Common Type: 4 channels for 2 COMs (single common)
Power Consumption: Max. 35 mA @ 5 VDC

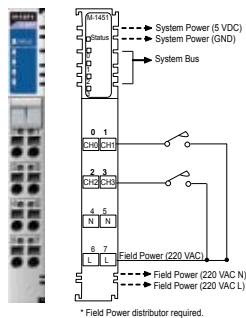

M-1451: 4 digital inputs, 220 VAC

Inputs per Module: 4 channels
On-state Voltage: 240 VAC nominal, min. 170 VAC to max. 264 VAC
Min. Off-state Voltage: Max. 45 VAC
On-state Current: Max. 12 mA/point @ 264 VAC
Input Impedance: Typ. 22K ohms
Common Type: 4 channels for 2 COMs (single common)
Power Consumption: Max. 35 mA @ 5 VDC



Ordering Information

		DC-Digital Input Modules				AC-Digital Input Modules	
Specs	Model	M-1800	M-1801	M-1600	M-1601	M-1450	M-1451
	Channels	8	8	16	16	4	4
	Sink/Source	Sink	Source	Sink	Source	---	---
	Connector	RTB	RTB	20-pin	20-pin	RTB	RTB
	Voltage	24 VDC	24 VDC	24 VDC	24 VDC	110 VAC	220 VAC
Isolation		Optical Isolation					



Digital Output Modules

8-channel 24 VDC digital output modules

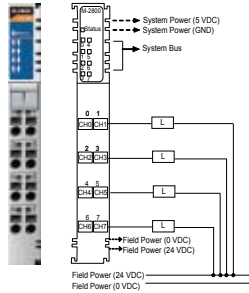

M-2800: 8 digital outputs, sink, 24 VDC, 0.5 A

- Outputs per Module:** 8 channels, sink type
- Output Voltage Range:** 24 VDC nominal, min. 11 VDC to max. 28.8 VDC
- On-state Voltage Drop:** Max. 0.3 VDC @ 25°C
- On-state Current:** Min. 1 mA per channel
- Off Leakage Current:** Max. 50 µA
- Output Current Rating:** Max. 0.5 A per channel
- Common Type:** 8 channels per external common (single common)
- Power Consumption:** Max. 60 mA @ 5 VDC

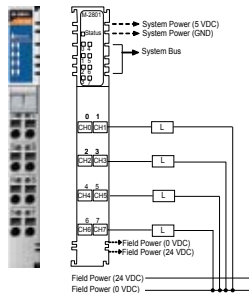

M-2801: 8 digital outputs, source, 24 VDC, 0.5 A

- Outputs per Module:** 8 channels, source type
- Output Voltage Range:** 24 VDC nominal, min. 11 VDC to max. 28.8 VDC
- On-state Voltage Drop:** Max. 0.3 VDC @ 25°C
- On-state Current:** Min. 1 mA per channel
- Off Leakage Current:** Max. 50 µA
- Output Current Rating:** Max. 0.5 A per channel
- Common Type:** 8 channels per external common (single common)
- Power Consumption:** Max. 60 mA @ 5 VDC



16-channel digital output modules

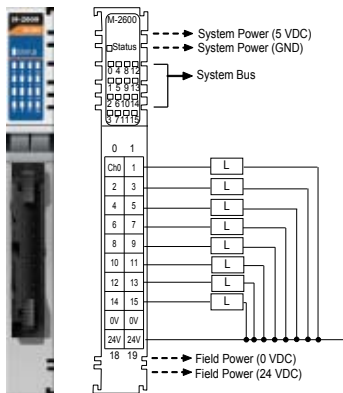

M-2600: 16 digital outputs, sink, 24 VDC, 0.3 A

- Outputs per Module:** 16 channels, sink type
- Output Voltage Range:** 24 VDC nominal, min. 11 VDC to max. 28.8 VDC
- On-state Voltage Drop:** Max. 0.3 VDC @ 25°C
- On-state Current:** Min. 1 mA per channel
- Off Leakage Current:** Max. 50 µA
- Output Current Rating:**
 - Max. 0.3 A per channel
 - Max. 4 A per common
- Common Type:** 16 channels for 2 COMs (single common)
- Power Consumption:** Max. 80 mA @ 5 VDC



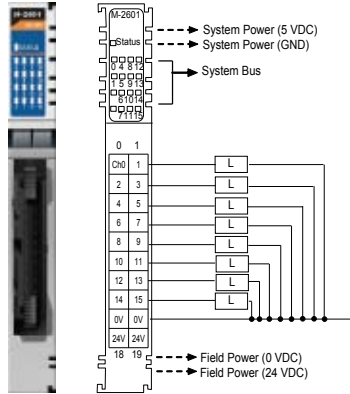

M-2601: 16 digital outputs, source, 24 VDC, 0.3 A

- Outputs per Module:** 16 channels, source type
- Output Voltage Range:** 24 VDC nominal, min. 11 VDC to max. 28.8 VDC
- On-state Voltage Drop:** Max. 0.3 VDC @ 25°C
- On-state Current:** Min. 1 mA per channel
- Off Leakage Current:** Max. 50 µA
- Output Current Rating:**
 - Max. 0.3 A per channel
 - Max. 4 A per common
- Common Type:** 16 channels for 2 COMs (single common)
- Power Consumption:** Max. 80 mA @ 5 VDC



4-channel relay output modules

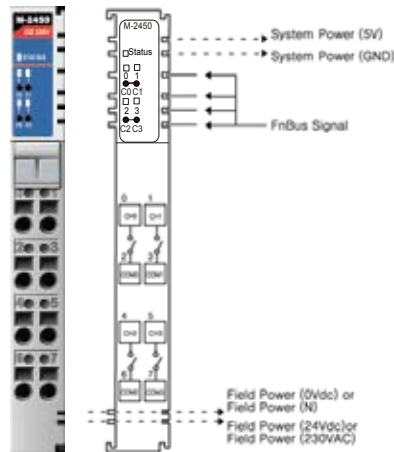

M-2450: 4 relay outputs, 24-VDC/230-VAC, 2 A

- Outputs per Module:** 2 channels, relay
- Relay Type:**
 - Form A, Normally Open (N.O.)
 - Single Pole, Single Throw (SPST)
- Output Voltage Range:** Load dependent
 - 5 to 28.8 VDC @ 2 A resistive
 - 48 VDC @ 0.8 A resistive
 - 110 VDC @ 0.3 A resistive
 - 250 VAC @ 2 A resistive
- Output Current Rating:** At rated power
 - 2 A @ 5 to 28.8 VDC
 - 0.8 A @ 48 VDC
 - 0.5 A @ 110 VDC
 - 2 A @ 250 VAC
- Min. Load:** 100 µA, 100 m VDC per point
- Max. On-state Voltage Drop:** 0.5 V @ 2 A, resistive load, 24 VDC
- Off-state Leakage Current:** Max. 1.5 mA
- Common Type:** 1 channel for 1 COM
- Power Consumption:** Max. 65 mA @ 5 VDC



Ordering Information

Digital Output Modules						
Specs	Model	M-2800	M-2801	M-2600	M-2601	M-2450
	Channels	8	8	16	16	4
	Sink/Source	Sink	Source	Sink	Source	Relay
	Connector	RTB	RTB	20-pin	20-pin	RTB
	Voltage	24 VDC	24 VDC	24 VDC	24 VDC	230 VAC/ 24 VDC
	Current	0.5A	0.5A	0.3A	0.3A	2.0A
	Isolation	Optical isolation				
	Diagnostics	---	---	---	---	---



Analog Input Modules

8-channel analog input modules, 12-bit resolution

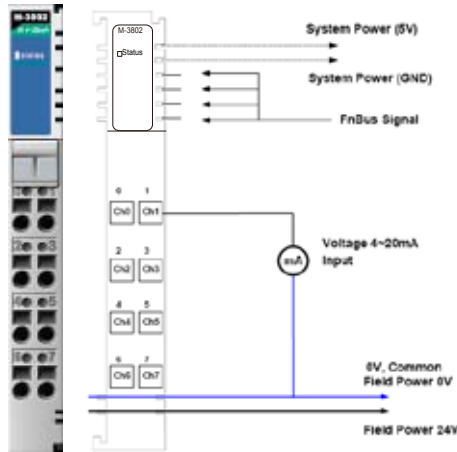

M-3802: 8 analog inputs, 4 to 20 mA, 12 bits

- Resolution in Ranges:** 12 bits, 3.91 $\mu\text{A}/\text{bit}$
- Input Current Range:** 0 to 20 mA
- Data Format:** 16-bit integer (2's complement)
- Accuracy:**
 - $\pm 0.1\%$, FSR @ 25°C
 - $\pm 0.3\%$, FSR @ 0°C, 60°C
- Input Impedance:** 120 ohms
- Conversion Time:** 4 ms for all channels
- Power Consumption:** Max. 150 mA @ 5 VDC
- Isolation:** I/O to logic (photocoupler isolation)
- Wiring:** I/O cable max. AWG14

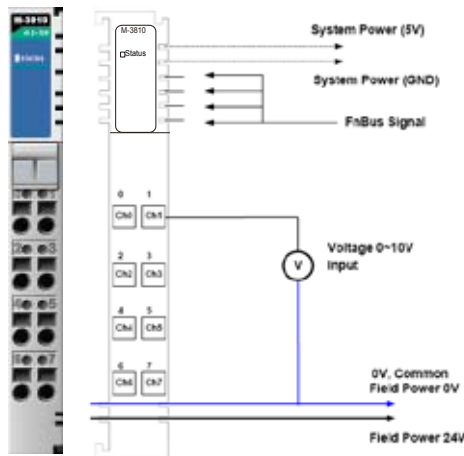

M-3810: 8 analog inputs, 0 to 10 V, 12 bits

- Resolution in Ranges:** 12 bits, 2.44 mV/bit
- Input Current Range:** 0 to 10 VDC
- Data Format:** 16-bit integer (2's complement)
- Accuracy:**
 - $\pm 0.1\%$, FSR @ 25°C
 - $\pm 0.3\%$, FSR @ 0°C, 60°C
- Input Impedance:** 500K ohms
- Conversion Time:** 4 ms for all channels
- Power Consumption:** Max. 150 mA @ 5 VDC
- Isolation:** I/O to logic (photocoupler isolation)
- Wiring:** I/O cable max. AWG14





Temperature Input Modules

2-channel temperature input modules, RTD or thermocouple input

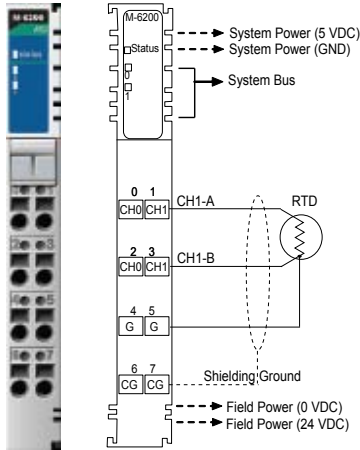

M-6200: 2 analog inputs, RTD: PT100, JPT100

Sensor Types:

- PT50, PT100, PT200, PT500, PT1000 (resistance 100 milli-ohms/bit)
- JPT100, JPT200, JPT500, JPT1000 (resistance 10 milli-ohms/bit)
- NI100, NI200, NI500, NI1000, NI120, CU10 (resistance 20 milli-ohms/bit)

Resolution: 0.1°C/10 milli-ohms

Data Format: 16-bit integer (2's complement)

Accuracy:

- ±0.1%, FSR @ 25°C
- ±0.3%, FSR @ 0°C, 60°C

Input Impedance: 500K ohms

Conversion Time: 200 ms for all channels

Diagnostics: Range over (if range over, data=Dx8000)

Power Consumption: Max. 80 mA @ 5 VDC

Isolation: I/O to logic (photocoupler isolation)

Wiring: I/O cable max. AWG14

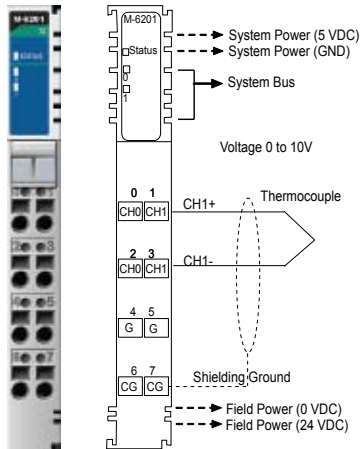

M-6201: 2 analog inputs, thermocouple

Sensor Types:

Type J/K/T/E/R/S/B/N/L/U/C/D
(mV input 10 µV/bit, 2 µV/bit)

Resolution: 0.1°C/10 µV

Data Format: 16-bit integer (2's complement)

Accuracy:

- ±0.1%, FSR @ 25°C
- ±0.3%, FSR @ 0°C, 60°C

Input Impedance: 500K ohms

Conversion Time: 200 ms for all channels

Diagnostics: Range over (if range over, data=Dx8000)

Power Consumption: Max. 80 mA @ 5 VDC

Isolation: I/O to logic (photocoupler isolation)

Wiring: I/O cable max. AWG14



Ordering Information

Analog Input Modules

	Model	M-3802	M-3810	M-6200	M-6201
Specs	Channels	8	8	2	2
	Current	4 to 20 mA	---	---	---
	Voltage	---	0 to 10V	---	---
	Connector	RTB	RTB	RTB	RTB
	Resolution	12-bit	12-bit	---	---
	Isolation	Optical isolation			
	Sensor Input	---	---	RTD (ohm)	Thermo-couple (mV)



Analog Output Modules

4-channel analog output modules, 12-bit resolution

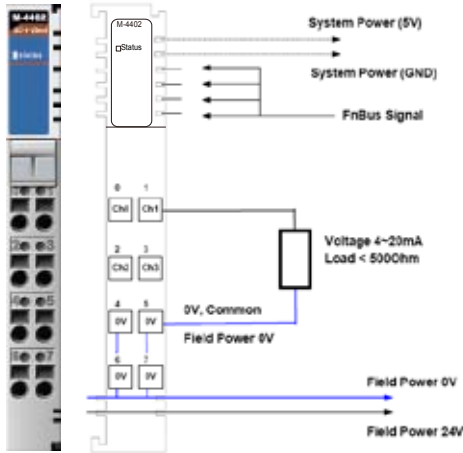

M-4402: 4 analog outputs, 4 to 20 mA, 12 bits

- Resolution in Ranges:** 12 bits, 3.91 μ A/bit
- Output Current Range:** 4 to 20 mA
- Data Format:** 16-bit integer (2's complement)
- Accuracy:**
 - $\pm 0.1\%$, FSR @ 25°C
 - $\pm 0.3\%$, FSR @ 0°C, 60°C
- Output Impedance:** Max. 500 ohms
- Conversion Time:** 2 ms for all channels
- Power Consumption:** Max. 65 mA @ 5 VDC
- Isolation:** I/O to logic (photocoupler isolation)
- Wiring:** I/O cable max. AWG14

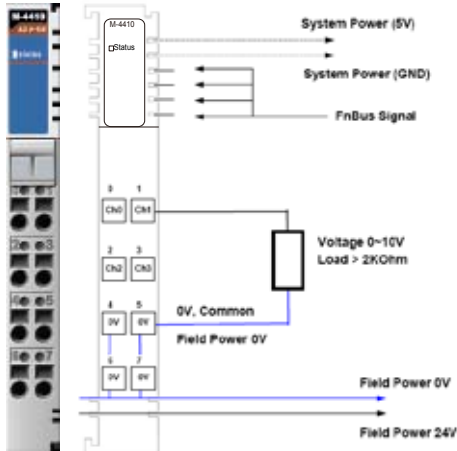

M-4410: 4 analog outputs, 0 to 10 V, 12 bits

- Resolution in Ranges:** 12 bits, 2.44 mV/bit
- Output Current Range:** 0 to 10 VDC
- Data Format:** 16-bit integer (2's complement)
- Accuracy:**
 - $\pm 0.1\%$, FSR @ 25°C
 - $\pm 0.3\%$, FSR @ 0°C, 60°C
- Output Impedance:** Max. 5K ohms
- Conversion Time:** 2 ms for all channels
- Power Consumption:** Max. 200 mA @ 5 VDC
- Isolation:** I/O to logic (photocoupler isolation)
- Wiring:** I/O cable max. AWG14



Ordering Information

Analog Output Modules

		M-4402	M-4410
Specs	Model	M-4402	M-4410
	Channels	4	4
	Current	4 to 20 mA	---
	Voltage	---	0 to 10V
	Connector	RTB	RTB
	Resolution	12-bit	12-bit
	Isolation	Optical Isolation	



Power Modules

When to Use a Power Module

System Power Distributor

The system power expansion module is designed to provide extra power for connected I/O expansion modules. Each NA-4000 series network adaptor can provide 1.5 A @ 5 VDC. If you need more power

for your installed I/O expansion modules, you will need to use an M-7001 module. However, note that the M-7001 can only provide 1.5 A @ 5 VDC.

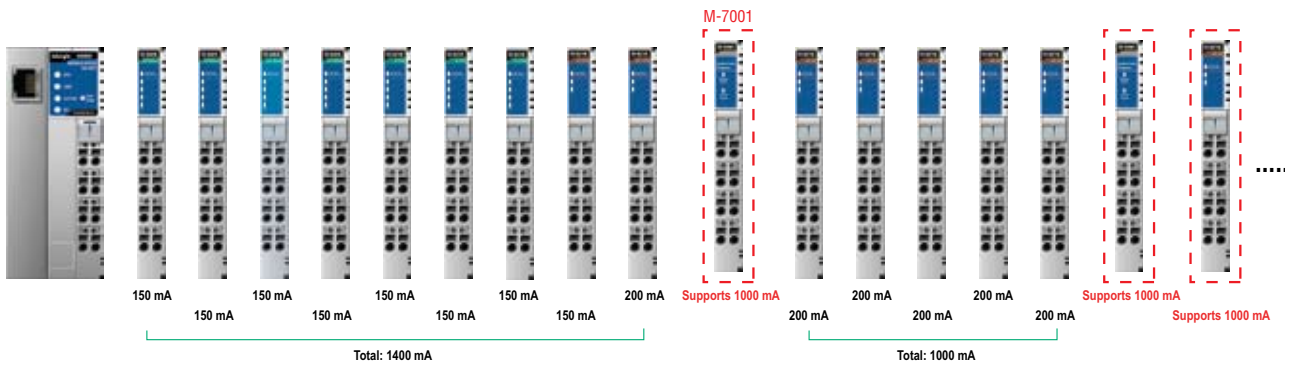

Field Power Distributor

The field power distributor is designed to isolate different field voltages. For example, before you connect a 48 VDC or 110 VAC DI/O

module to a 24 VDC DI/O module, you will need an M-7002 field power distributor.

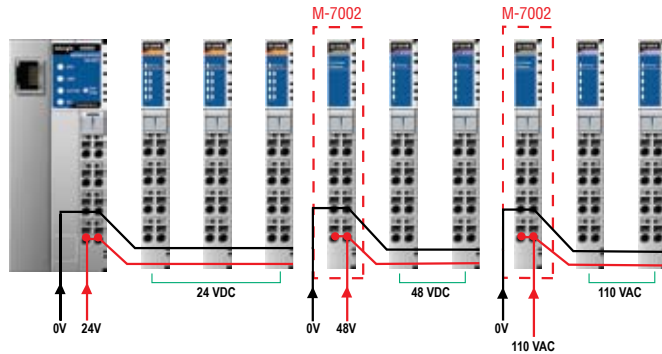

Potential Power Distributor

There are three types of potential distributor modules that provide extra wiring points, such as shielding ground, 0 V field power, and 24 V field power. For example, the 8-channel digital input (sink type)

module by itself does not have a 24 V wiring point. In this case, you can add an M-7805 for easier wiring.

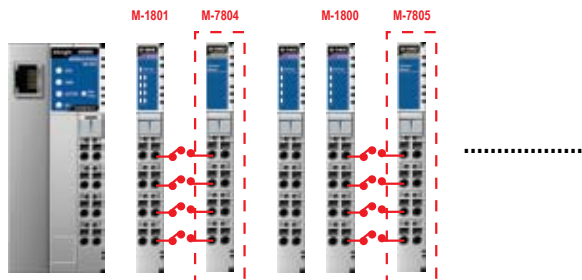

Power Modules

M-7001: System power module

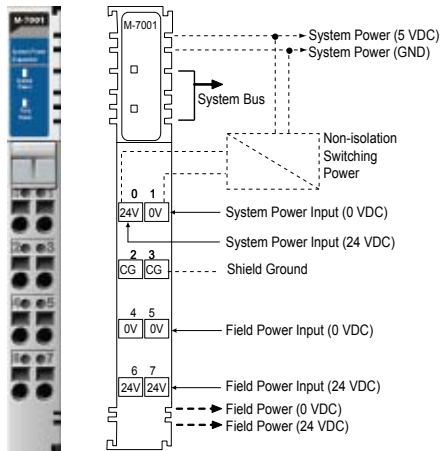

- **System Input Voltage:** 24 VDC, 11 to 28.8 VDC
- **Field Power Input Voltage:** 24 VDC ($\pm 20\%$)
- **Current for I/O Modules:** 1.5 A @ 5 VDC (Max.)
- **System Bus Output Voltage:** 5 VDC (Max.)
- **Field Power Contacts Current:** 10 A (Max.)

M-7002: Field power module

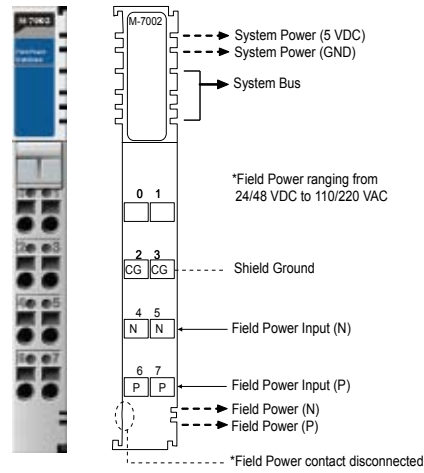

- **Field Power Input Voltage:**
DC: 5 VDC, 24 VDC, 48 VDC
AC: 110 VAC, 220 VAC
- **Current for Field Power Contacts:** 10 A (Max.)

M-7804: 0 VDC

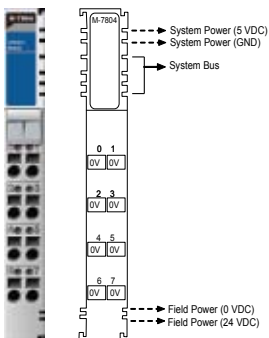

Channels: 8
Mode: 0 VDC

M-7805: 24 VDC

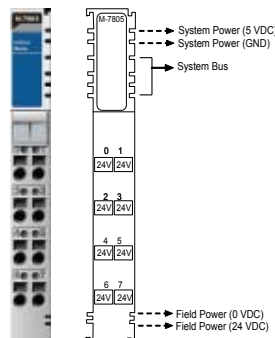

Channels: 8
Mode: 24 VDC

Ordering Information

Power Modules					
Specs	Model	M-7001	M-7002	M-7804	M-7805
	Channels	0	0	8	8
	Voltage	24 VDC	DC: 5, 24, 48 VDC AC: 110/220 VAC	0 VDC	24 VDC
	Purpose	System Power	Field Power	Field Power	Field Power

Modular I/O Accessories



TB 1600 DIN-Rail mounting screw terminal module with 20-pin connector

- 20 pins, one-to-one assignment
- Connector pitch: 3.81 mm
- DIN-Rail mounting type
- Dimensions: 77.5 x 67.5 x 51 mm (3.05 x 2.66 x 2.01 in)
- RoHS compliant



20-to-20-pin flat cable

- Connects between the TB 1600 and ioLogik 4000 series
- Length: 500 mm
- Number of Pins: 20



M-8001-PK Removable terminal block

- Terminal block for the ioLogik 4000 series
- Packaging: 9 pcs in one box



M-8003-PK Marker with 0 to 9 numbering

M-8004-PK Blank marker

- Marker for the ioLogik 4000 series
- Packaging: 100 pcs in one box

Ordering Information

- **TB 1600:** DIN-Rail mounting screw terminal module with 20-pin connector
- **20-to-20-pin flat cable:** 20-pin to 20-pin flat cable, 500 mm
- **M-8001-PK:** Removable terminal block, 9 pcs per pack
- **M-8003-PK:** Marker with 0 to 9 numbering, white color, 100 pcs
- **M-8004-PK:** Blank marker, 100 pcs