

# Double Gang Junction Box

## PRODUCT SPECIFICATION

### Package includes:

- A. Double Gang Junction Box Cover, 1 pc
- B. Double Gang Junction Box Base, 1 pc
- C. Double Sided Adhesive Strip, 2 pcs
- D. 4" Cable Tie, 4 pcs
- E. #6-32 x 3/4" Pan Head, Sharp Point Tapping Screw, 4 pcs

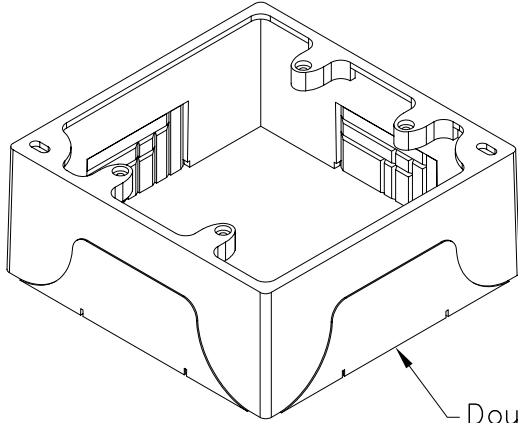

Double Gang Junction Box Cover

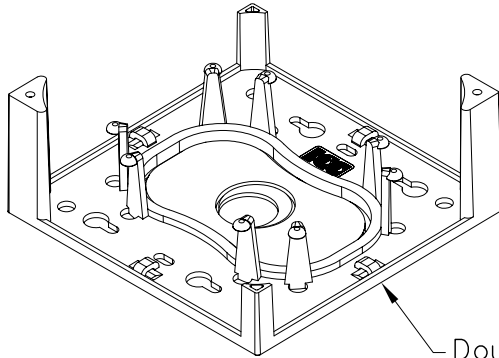

Double Gang Junction Box Base

### Features and Benefits:

- 2-piece design provides a surface mounted solution for a variety of media, including voice, data, CATV, fiber, audio and video distribution to the work area
- Fits standard NEMA double gang electrical boxes
- Multiple mounting options including adhesive backings and screws
- Integrated internal routing posts and cable management system with evenly spaced cable tie anchor points
- Rear cable entry for clean external appearance
- Rugged and durable construction
- Raceway knockouts integrate with raceway systems
- Used with ICRW11, ICRW12, and ICRW13 raceway systems
- Accommodates all ICC faceplates
- Available in gray, ivory, and white
- UL listed

### JUNCTION BOX, 2-GANG

ITEM NO. ICACSMBDXX  
 DWG NO. PSACSMBD00

REV. A  
 PAGE NO. 1



CUSTOMER CARE / TECHNICAL SUPPORT \* CSR@ICC.COM / 888-ASK-4-ICC (275-4422) \* 16800 Edwards Road, Cerritos, CA 90703 \* Phone 562-356-3111 \* Fax 562-356-3100 \* www.icc.com

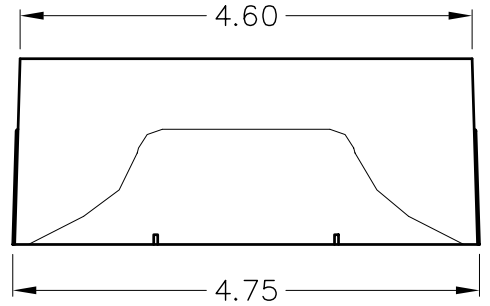
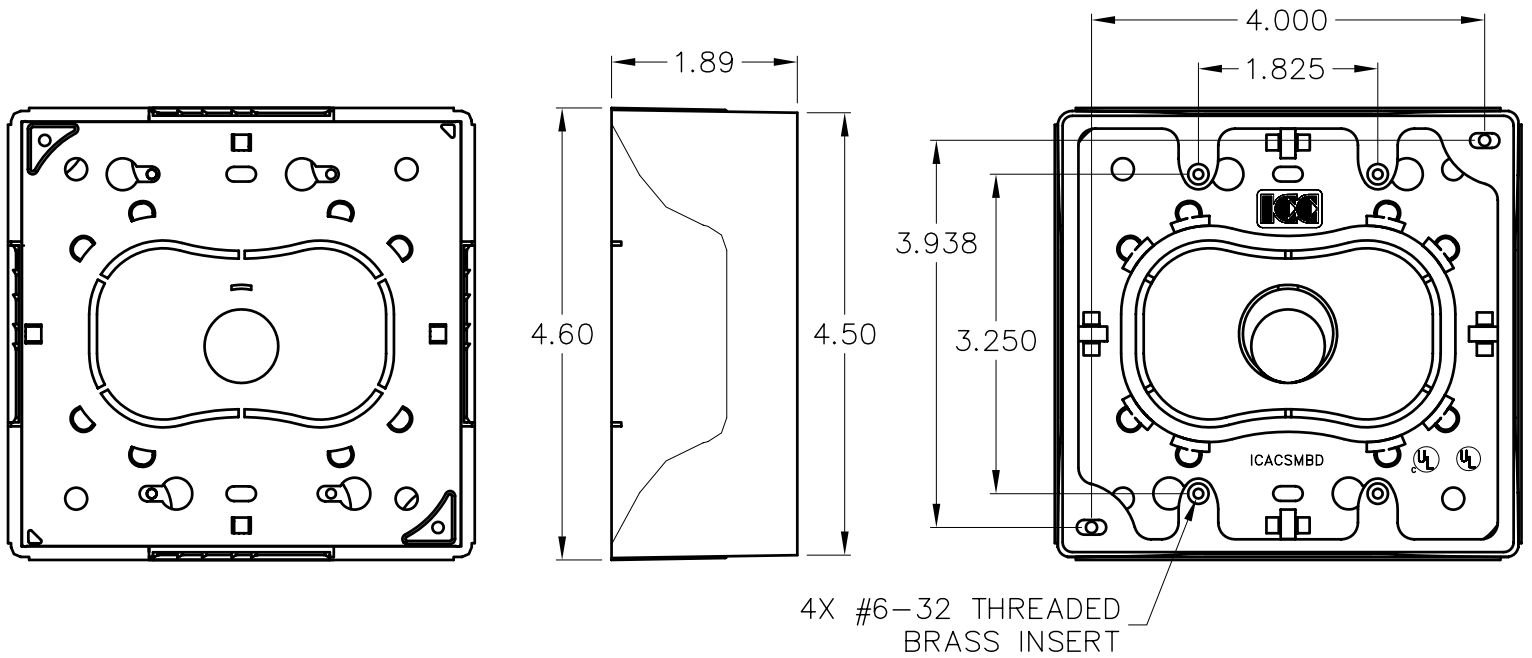

**NOTE: UNLESS OTHERWISE SPECIFIED**

1. MATERIAL: ABS, UL 94V-0
2. SURFACE FINISHING: TEXTURE
3. COLOR: XX: GY- GRAY, IV-IVORY, & WH-WHITE
4. KNOCKOUT DIMENSIONS: .80"X.55", 1.30"X.85", & 1.80"X1.05"

UL US FILE NO. 125268

**JUNCTION BOX, 2-GANG**

ITEM NO. ICACSMBDXX  
 DWG NO. PSACSMBD00

REV. A  
 PAGE NO. 2



CUSTOMER CARE / TECHNICAL SUPPORT \* CSR@ICC.COM / 888-ASK-4-ICC (275-4422) \* 16800 Edwards Road, Cerritos, CA 90703 \* Phone 562-356-3111 \* Fax 562-356-3100 \* www.icc.com