

Transcend 40-Pin IDE Flash Module

Description

With an IDE interface and strong data retention ability, 40-Pin IDE Flash Modules are ideal for use in the harsh environments where Industrial PCs, Set-Top Boxes, etc. are used.

Placement

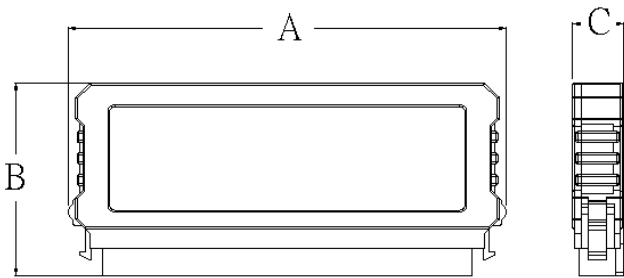

Features

- RoHS compliant products
- Storage Capacity: 128MB ~ 2GB
- Operating Voltage: 3.3V or 5V
- Operating Temperature: 0°C ~ 70°C
- Endurance: 1,000,000 Program/Erase cycles
- MTBF: 1,000,000 hours
- Durability of Connector: 10,000 times
- Fully compatible with devices and OS that support the IDE standard (pitch = 2.54mm)
- Built-in ECC function assures high reliability of data transfer
- Auto Sleep and Power-Down modes supported

Dimensions

Side	Millimeters	Inches
A	61.00 ± 0.40	2.402 ± 0.016
B	26.90 ± 0.20	1.059 ± 0.008
C	7.10 ± 0.15	0.280 ± 0.004

Transcend 40-Pin IDE Flash Module

Pinouts

Pin No.	Pin Name	Pin No.	Pin Name	Pin No.	Pin Name	Pin No.	Pin Name
01	RESET	11	HD3	21	NC	31	IREQ
02	GND	12	HD12	22	GND	32	IOIS16B
03	HD7	13	HD2	23	IOWB	33	HA1
04	HD8	14	HD13	24	GND	34	PDIAGB
05	HD6	15	HD1	25	IORB	35	HA0
06	HD9	16	HD14	26	GND	36	HA2
07	HD5	17	HD0	27	NC	37	CE1B
08	HD10	18	HD15	28	NC	38	CE2B
09	HD4	19	GND	29	NC	39	DASPB
10	HD11	20	VCC	30	GND	40	GND

Input Power

The 40-Pin IDE Flash Module offers 2 ways to get input power, either via the small power cord or through Pin 20 of the IDE connector. If Pin 20 of the IDE connector is defined as NC (No Connect), then the 40-Pin IDE Flash Module must be directly connected to your system's power supply. If Pin 20 of the IDE connector is defined as VCC, then the 40-Pin IDE Flash Module can get necessary power without use of the power cord.

Pin Definition

Symbol	Function
HD0 ~ HD15	Data Bus (Bi-directional)
HA0 ~ HA2	Address Bus (Input)
RESET	Device Reset (Input)
IORB	Device I/O Read (Input)
IOWB	Device I/O Write (Input)
IOIS16B	Transfer Type 8/16 bit (Output)
CE1B, CE2B	Chip Select (Input)
PDIAGB	Pass Diagnostic (Bi-directional)
DASPB	Disk Active/Slave Present (Bi-directional)
IREQ	Interrupt Request (Output)
NC	No Connection
GND	Ground
VCC	Vcc Power Input

Transcend 40-Pin IDE Flash Module

Block Diagram

With 1 pcs of Flash Memory:

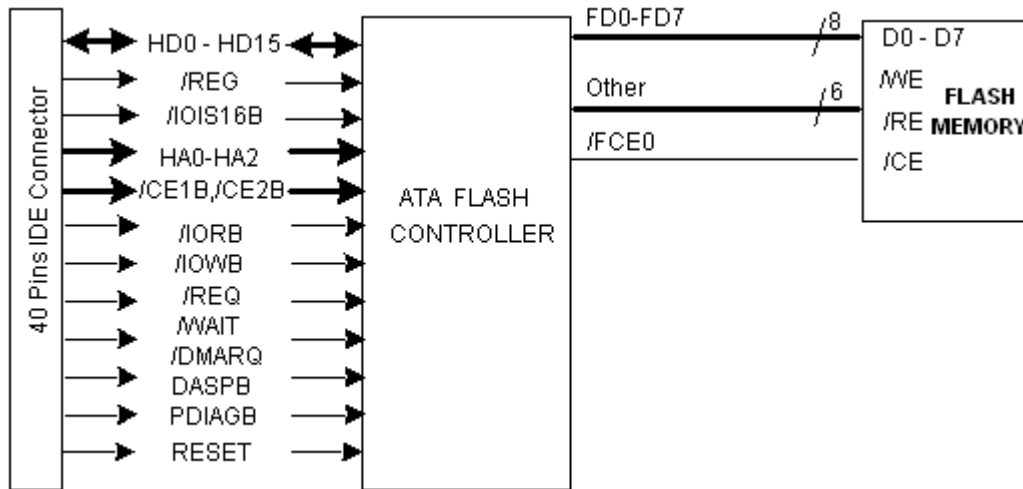

With 2 pcs of Flash Memory:

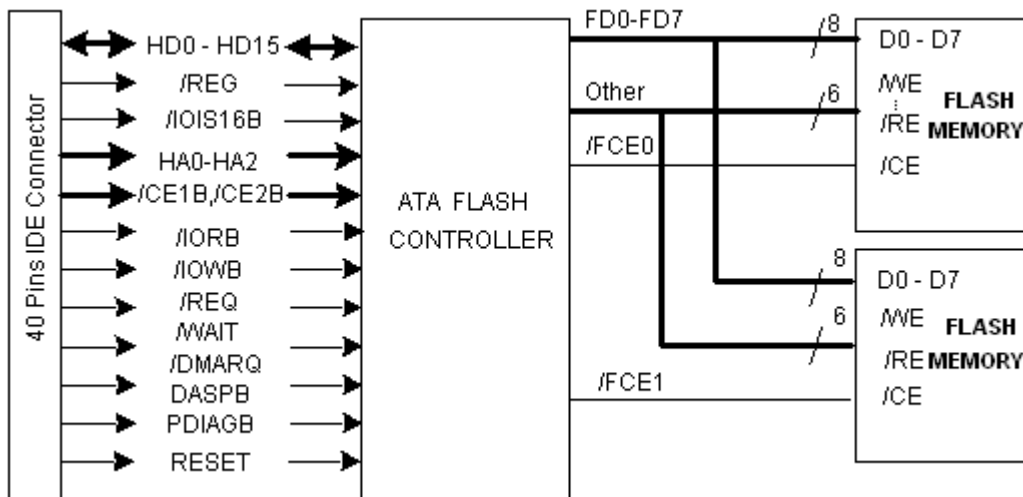

Transcend 40-Pin IDE Flash Module

Absolute Maximum Ratings

Symbol	Parameter	Min	Max	Unit
VDD-VSS	DC Power Supply	-0.6	+6	V
Vcc	Power Supply Voltage	-0.3	3.6	V
Ta	Operating Temperature	0	+70	°C
Tst	Storage Temperature	-55	+150	°C

Recommended Operating Conditions

Symbol	Parameter	Min	Max	Units
VDD	Power supply	3.0	5.5	V
VIN	Input voltage	0	VDD+0.3	V
Ta	Operating Temperature	0	+85	°C

DC Characteristics (Ta=0 °C to +70 °C, Vcc = 3.3V ±10%)

Parameter	Symbol	Conditions	Min	Typ	Max	Unit
Input Voltage	VIH	--	2	--	--	V
	VIL	--	--	--	0.2 x Vcc	V
Output Voltage	VOH	IOH = 4,8mA	Vcc - 0.8	--	--	V
	VOL	IOL = 4,8mA	--	--	0.4	V
Input leakage current	ILK	VIH = VDD / VIL = GND	-1	--	1	uA
Sleep current	ISP	--	--	0.5	1	mA

Transcend 40-Pin IDE Flash Module

True IDE Mode Access Read AC Characteristics

Parameter	Symbol	Min	Typ	Max	Unit
Data delay after IORD	td(IORD)	—	—	50	ns
Data hold following IORD	th(IORD)	5	—	—	ns
IORD width time	tw(IORD)	70	—	—	ns
Address setup before IORD	tsuA(IORD)	15	—	—	ns
Address hold following IORD	thA(IORD)	10	—	—	ns
CE setup before IORD	tsuCE(IORD)	5	—	—	ns
CE hold following IORD	thCE(IORD)	10	—	—	ns
IOIS16 delay falling from address	tdfIOIS16(ADR)	—	—	35	ns
IOIS16 delay rising from address	tsfIOIS16(ADR)	—	—	35	ns

True IDE Mode Access Read Timing

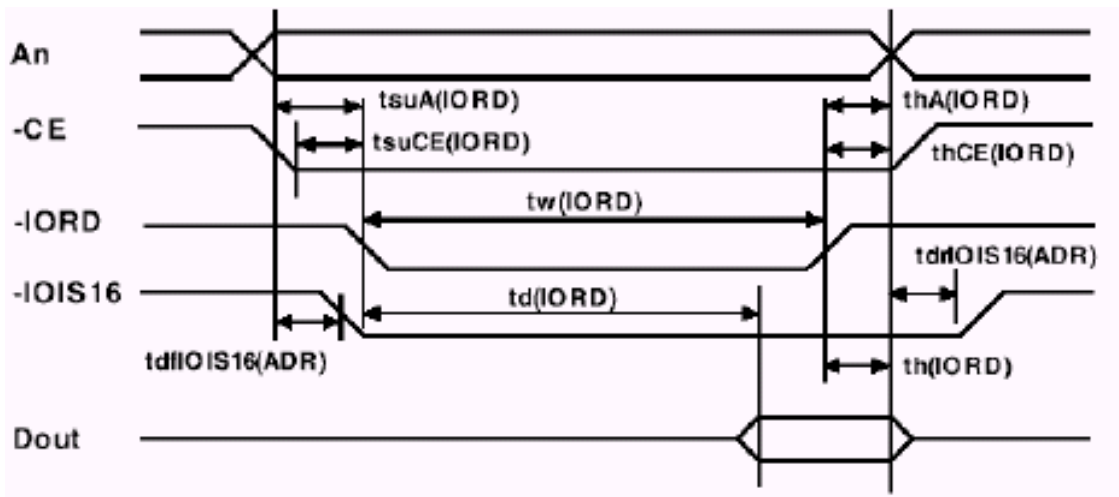

Transcend 40-Pin IDE Flash Module

True IDE Mode Access Write AC Characteristics

Parameter	Symbol	Min	Typ	Max	Unit
Data setup before IOWR	tsu(IOWR)	20	—	—	ns
Data hold following IOWR	th(IOWR)	10	—	—	ns
IOWR width time	tw(IOWR)	50	—	—	ns
Address setup before IOWR	tsuA(IOWR)	15	—	—	ns
Address hold following IOWR	thA(IOWR)	10	—	—	ns
CE setup before IOWR	tsuCE(IOWR)	5	—	—	ns
CE hold following IOWR	thCE(IOWR)	10	—	—	ns
IOIS16 delay falling from address	tdfIOIS16(ADR)	—	—	35	ns
IOIS16 delay rising from address	tsfIOIS16(ADR)	—	—	35	ns

True IDE Mode Access Write Timing

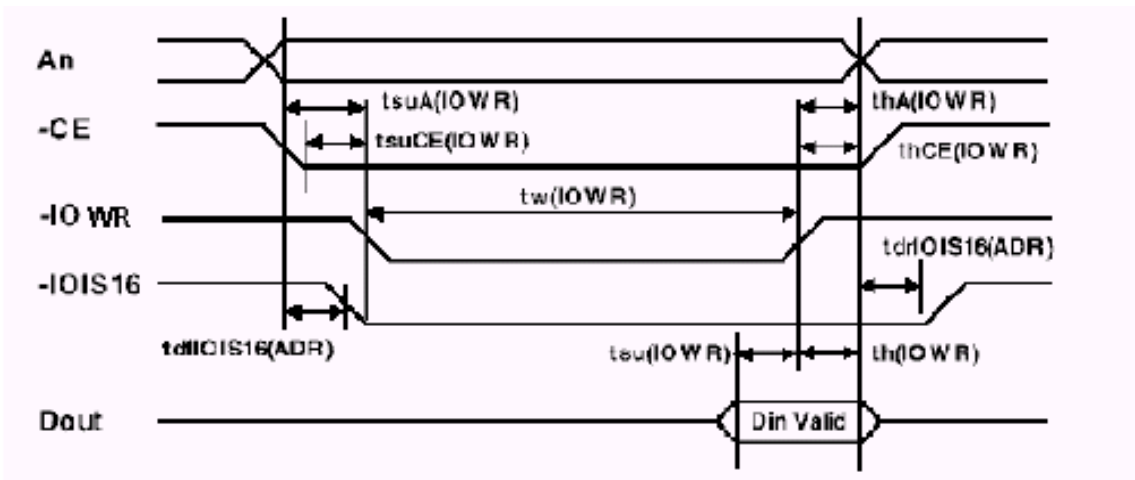

Above technical information is based on industry standard data and tested to be reliable. However, Transcend makes no warranty, either expressed or implied, as to its accuracy and assumes no liability in connection with the use of this product. Transcend reserves the right to make changes in specifications at any time without prior notice.