

F&eIT Series
Ethernet Data Acquisition and Controlling Module
CPU-CA20(FIT)GY



* Specifications, color and design of the products are subject to change without notice.

Features

The module does not require a fan as it uses a low power CPU with low heat dissipation. The compact design means it can be installed anywhere.

The module controls connected device modules such as digital I/O, and transfers monitoring and control data to and from a host PC or server unit via Ethernet.

The module can be used as part of a web-based system in conjunction with a F&eIT series I/O Assist Server Unit [SVR-IOAx(FIT)GY]*1 and Monitoring and Control Server Unit [SVR-MMFx(FIT)GY]*1.

The supplied driver library makes it easy to monitor and control external devices via a network from a host PC. Control applications can also be developed on UNIX and other non-Windows operating systems by using standard socket calls.

As in the case of other members of the F&eIT series, a mechanism for attachment to the 35mm DIN rail is provided in the system unit as a standard item. The system features a unique configuration that enables it to be connected to a module on the side in a stacking manner, which allows you to configure the system simply and elegantly without using backplanes and other connecting devices

*1 The "x" in a model code represents a single digit (or no digit) indicating different products. (The same convention applies below).

This product is a controller module for transferring I/O data between a host PC and network. It can be used to process I/O signals from connected F&eIT series device modules. You can connect any combination of digital I/O, analog I/O, counter inputs, or other device modules (up to a maximum of eight modules).

The latest information on which device modules can be used is included in the Readme file on the supplied CD. If updating to the latest firmware, refer to the Readme file for the firmware.

Specification

Product Specifications

Item	Specs
CPU	SH4 240MHz
Memory	Flash ROM: 4Mbyte(32Mbit) SDRAM : 32Mbyte(256Mbit)
LAN controller	National Semiconductor DP83815 10/100BASE-TX controller Internal send (2KByte) and receive (2KByte) buffers Full duplex-capable
Interface (host side)	10/100BASE-TX(IEEE802.3u)
Interface (device side)	CONTEC original 8-bit bus
Number of connectable devices	8 units max. *1
Module connection method	Device units are directly connected to the right side of the system. Connection mechanisms are provided on the system unit as standard items.
Power supply voltage	Power is supplied by means of a 2-piece power input connector (detachable), 5VDC ±5%, on the front side. Use of a F&eIT series power supply unit or an off-the-shelf stabilized power supply unit is recommended.
Power consumption-current	0.7A(Max.) *2 (Exclusive of any power that is supplied to the device module)
FG pin	Power supply connector equipped with a FG pin.
External dimensions (mm)	25.2(W)×64.7(D)×94.0(H) (exclusive of any protrusions)
Weight	100g
Installation method	One-touch installation on a 35-mm DIN rail. The module includes a DIN rail mounting mechanism as a standard feature.

*1 The sum of maximum current requirements of the units may not exceed the rated output current for the power supply unit.

*2 The power for the device modules is supplied by means of a stack connector. The maximum allowable current on the stack connector is 3.0 A.

Installation Environment Requirements

Parameter	Requirement description
Operating temperature	0 - 50 °C
Storage temperature	-10 - 60°C
Humidity	10 - 80%RH (No condensation)
Floating dust particles	Not to be excessive
Corrosive gases	None
Line-Noise resistance	Line-noise *3 AC line/2kV, Signal line/1kV (IEC1000-4-4Level 3, EN61000-4-4Level 3)
	Static electricity resistance Contact discharge/4kV (IEC1000-4-2Level 2, EN61000-4-2Level 2) Atmospheric discharge/8kV (IEC1000-4-2Level 3, EN61000-4-2Level 3)
Impact resistance	Sweep resistance 10 - 57Hz/semi-amplitude 0.15mm, 57 - 150Hz/2.0G
	80minutes each in X, Y, and Z directions (JIS C0040-compliant, IEC68-2-6-compliant)
Impact resistance	15G, half-sine shock for 11ms in X, Y, and Z directions (JIS C004-compliant, IEC68-2-27-compliant)
Grounding	Class D grounding (previous class 3 grounding)

*3 When POW-AD22GY used

Packing List

Module [CPU-CA20(FIT)GY] ...1
 First step guide ... 1
 CD-ROM [F&eIT Series Setup Disk] *1 ...1
 Power connector ...1

*1 The CD-ROM contains various software and User's Manual.

Physical Dimensions

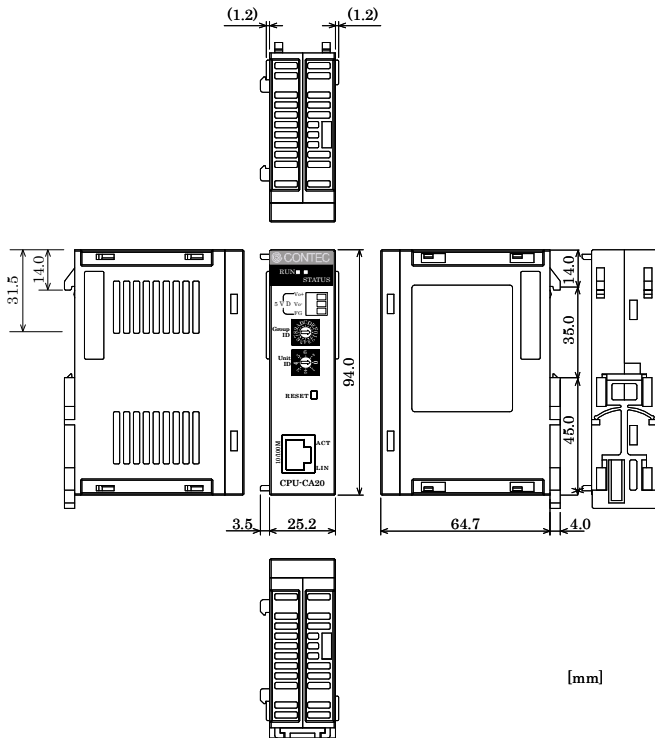

[mm]

System Configuration Image

This product is an I/O controller module for processing I/O signals from connected device modules and transferring this data via a network to or from a PC or other host device.

When connected to a device module, the I/O Controller Module forms an I/O Controller Unit.

When used in conjunction with an I/O Assist Server Unit (SVR-IOAx(FIT)GY), the I/O Controller Unit can collect data and perform management functions, such as loading data onto the I/O Controller Unit itself.

Multiple I/O controller units and I/O assist server units (a maximum of eight units) can be installed on the same network. In this manner, when connected to an I/O assist server unit, a host controller can input and output signals to and from the devices that are connected to a subordinate I/O controller unit.

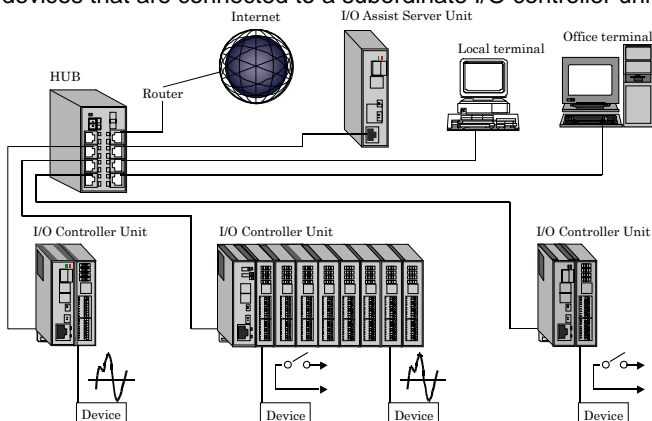

Nomenclature

I/O Assist Server Unit:

The I/O Assist Server Unit supports the management function that enables it to collect data from, and set data to, I/O controller units that belong to the same group as the Group ID that is set by using the Group ID switches of the SVR-IOAx(FIT)GY ("Assist Server"), which is a CONTEC product. Group IDs can be set in a range of 0 - 7. By connecting local terminals and office terminals by means of a Web browser, it is possible to monitor the status of the devices that are connected to an I/O controller unit.

I/O Controller Unit:

The I/O Controller Unit is a general term that refers to any combination of this product, with device modules. Each device contains a Group ID SW and a Unit ID SW; these switches must be set so that they are unique within the network. The I/O Controller Unit transmits data collected from the devices to the I/O Assist Server Unit that bears a specified Group ID. The Group ID for this product can be set in the range 0 - 8 and A. The Unit ID can be set in the range 0 - 7. If the Group ID is set to A, the Unit ID can be set in the range 0 - 7Fh, permitting up to 128 devices. Data cannot be sent to an I/O Assist Server if the Group ID is set to 8 or A. Control of the I/O controller unit can be performed directly from a terminal. Further details on this topic may be found in the respective device module manuals.

HUB:

This is a line concentration device that is used when a LAN is constructed using twisted-pair cables. The F&eIT series includes an 8-port switching HUB unit (SH-8008(FIT)H) that is equipped with a DIN rail mounting mechanism.

F&eIT Protocol Specifications

The sudden spread of the Internet has resulted in networks springing up in a wide range of fields. This, in turn, has resulted in the appearance of many information devices that make use of this infrastructure. Yet, it is a fact that interconnectivity - the greatest advantage of networks - is not being used to its fullest. CONTEC sees networks as a prime part of the system bus concept and has developed distributed monitor & control networks that organically integrate various applications from corporate offices through to field applications.

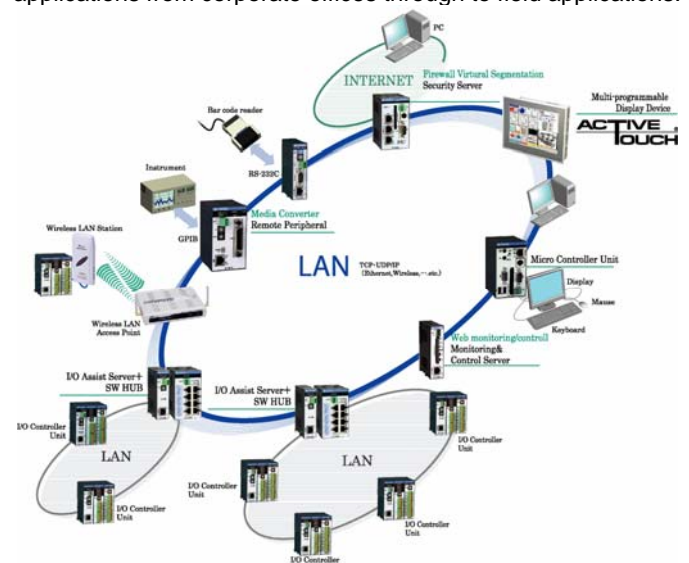

The following defines the common protocol layers that will be provided in all products based upon the communications server concept. Such products, complying with the communications server specifications, will be able to access device information using the same protocol.

The role of the F&eIT Protocol

The F&eIT Protocol defines the following protocol layers.

Application layer	
Device-dependent control layer	ACX, DLL, etc
F&eIT protocol layer	F&eIT protocol specifications
Transport layer	UDP, ICMP
Network layer	IP, ARP
Data link layer	Ethernet(IEEE802.3), etc
Physical layer	

Basic Specifications

Concepts

The F&eIT Protocol assigns all device resources (including information) to virtual space so that any access to a device will be performed by specifying a virtual address. The virtual space is divided into information common to devices, device-specific information, I/O space, and memory space. The specific location in the virtual space where information is stored and the method by which information is stored is completely transparent to where or how information is stored in actual physical resources.

00000000h - 000FFFFFh	Information common to devices (1M byte)
00100000h - 001FFFFFh	Device-specific information (1M byte)
00200000h - 002FFFFFh	Definition of device-specific information (1M byte)
00300000h - 003FFFFFh	I/O space (1M byte)
00400000h - 004FFFFFh	Memory space (1M byte)
FFE00000h - FFFFFFFFh	Firmware update area (1M byte)

Data Communications Protocol

The F&eIT Protocol has two access procedures on the connectionless UPD/IP: response-type access and trap-type access.

(Response-type)

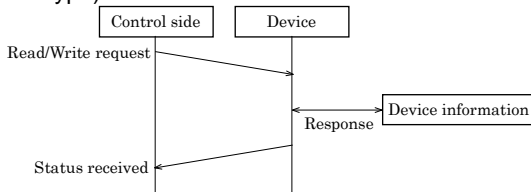

(Trap-type)

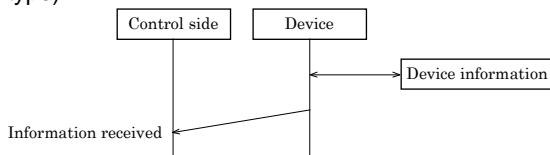

Setting a Group ID

By setting a Group ID, it is possible to manage the various operating modes (e.g., connecting an I/O assist server unit, starting the system on a stand-alone basis, or upgrading the system).

A Group ID can be set in a range of 0 - F.

Setup Method

A Group ID can be set by turning the rotary switch on the module face.

To set a Group ID, turn the switch knob.

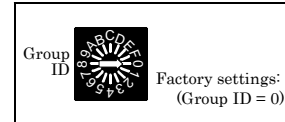

- 0 - 7 : I/O Assist Server Unit connection mode
- 8 : Stand-alone startup mode
- A : Stand-alone startup mode
- 9, B - D : Not used
- E : System recovery and firmware upgrade mode
- F : Initialization mode *1

⚠ CAUTION

A Group ID in the 0 - 7 range must be the same as the Group ID for the I/O Assist Server Unit.

When a CPU-CA20(FIT)GY is used with the Group ID set to "A" for standalone boot mode, use the utility software to set the Unit ID.

*1 About Initialization mode

Restore the setting of this product to its factory settings. Set the Group ID to "F" and turn the power on. RUN and STATUS LEDs will start to flash. Once these LEDs stop flashing and grow solid, all settings (IP address etc.) will be initialized and return to its factory settings after next boot.

Setting a Unit ID

By setting a Unit ID, it is possible to manage the units in the same group.

A Unit ID can be set in a range of 0 - 7 (8 possible positions).

Setup Method

A Unit ID can be set by turning the rotary switch on the device face.

To set a Unit ID, turn the switch knob.

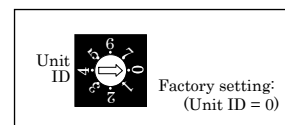

⚠ CAUTION

The Unit IDs in the same group must all be unique within the group.

When this product is used with the Group ID set to "A" for standalone boot mode, use the utility software to set the Unit ID.

Connection Method

Supplying the Power

The module and the DC-DC power supply (POW-DDxx) can be cable-connected using the detachable connector that is provided on the unit face. (Compatible cables: AWG28 - 16)

Third-party DC output power supply unit can also be connected in the same way.

⚠ CAUTION

The power for the device module is supplied from the stack connector.

As the DC-DC power supply generates heat, provide a gap of at least 2.0cm between the power supply and module to ensure the air vents are not obstructed.

The power supplied from the stack connector is 5.0VDC 3A. Although a maximum of eight units can be connected, be careful that the sum of the power requirements of the connected units is no greater than 3A.

Input power requirements: 5.0VDC±5%, 0.7A (Max.)

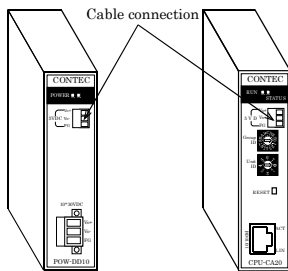

Product type	Module type	Current consumption (5.0VDC)
DIO-8/8(FIT)GY	Isolated digital I/O module (12 - 24VDC)	0.15A
DI-16(FIT)GY	Isolated digital input module (12 - 24VDC)	0.15A
DO-16(FIT)GY	Isolated digital output module (12 - 48VDC)	0.15A
DIO-8/8H(FIT)GY	Isolated digital I/O module (36 - 48VDC)	0.15A
DI-16H(FIT)GY	Isolated digital input module (36 - 48VDC)	0.15A
DIO-4/4(FIT)GY	Isolated digital I/O module (Input:12 - 24VDC, Output:12 - 48VDC)	0.15A
DI-8(FIT)GY	Isolated digital input module (12 - 24VDC)	0.15A
DO-8(FIT)GY	Isolated digital output module (12 - 48VDC)	0.15A
DIO-8D(FIT)GY	Non-isolated buffered bi-directional digital I/O module	0.15A
ADI12-8(FIT)GY	Isolated analog input module	0.35A
ADI16-4(FIT)GY	Isolated high-precision analog input module	0.3A
DAI12-4(FIT)GY	Isolated analog output module	0.40A
DAI16-4(FIT)GY	Isolated high-precision analog output module	0.50A
CNT24-2(FIT)GY	Isolated counter input module	0.15A

* Refer to the Readme file on the supplied CD for the latest information on the available device modules and their power consumption specifications.

Connecting to the SH-8008(FIT)H

These units are connected by means of an Ethernet interface.

In situations where many lower-level groups are used, a hub should be provided between those groups and this product.

(CONTEC recommends the use of the switching HUB unit SH-8008(FIT)H in the F&eIT series of products.)

Network cable

Cables complying with the following specifications should be used:

Category 3,4 UTP cable (for 10BASE-T)

Category 5 UTP cable (for 100BASE-TX)

