

4ch 24Bit  
Up/Down Counter Board for PCI

**CNT24-4(PCI)H**

with Driver Library [API-PAC(W32)]



**Features**

- It is equipped with four channels of 24-bit up/down counters.
- The board can count two-phase signals, which can be outputs of some rotary encoders and linear scales
- You can select either a photo coupler isolated input or a TTL-level input for each channel by software command.
- Each channel can generate an interrupt request signal and a one-pulse output signal when the count data matches a pre-specified value.
- The board is equipped with a programmable timer to allow interrupts to be generated periodically according to a specified timer value.
- Each Channel is equipped with a general-purpose input signal (both photo coupler and TTL).

**Product Configuration List**

- CNT24-4(PCI)H ... 1
  - First step guide ... 1
  - CD-ROM\*1 [API-PAC(W32)] ... 1
- \*1: The CD-ROM contains the driver software and User's Guide (this guide).

The CNT24-4(PCI)H is a PCI bus-compliant interface board that counts input pulse signals from external devices. The CNT24-4(PCI)H has four channels of 24-bit up/down counters, allowing external devices such as a rotary encoder and a linear scale to be connected. Given below are examples of using the board for "detecting a position of the table of a machine tool" and "detecting a change in weight".

The pulse signal inputting interface is photo coupler isolated or TTL-level input.

Using the bundled driver library [API-PAC(W32)], you can create Windows application software for this board in your favorite programming language supporting Win32 API functions, such as Visual Basic or Visual C/C++.

< Example >

- Detecting a position of the table of a machine tool

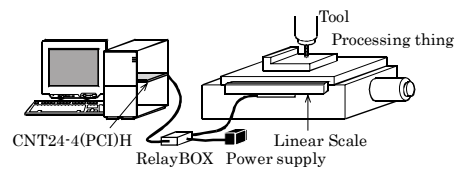

- Detecting a change in weight

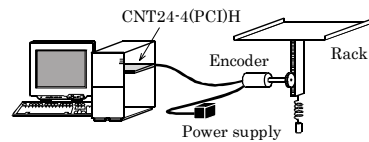

**Cable & Connector**

■ Cable & Connector (Option)

- Flat cable with both-ends 37-pin D-SUB connector
- : PCB37P-1.5 (1.5m)
  - : PCB37P-3 (3m)
  - : PCB37P-5 (5m)
- Shield cable with both-ends 37-pin D-SUB connector
- : PCB37PS-0.5P (0.5m)
  - : PCB37PS-1.5P (1.5m)
  - : PCB37PS-3P (3m)
  - : PCB37PS-5P (5m)
- Flat cable with one-end 37-Pin D-SUB connector
- : PCA37P-1.5 (1.5m)
  - : PCA37P-3 (3m)
  - : PCA37P-5 (5m)
- Shield cable with one-end 37-pin D-SUB connector
- : PCA37PS-0.5P (0.5m)
  - : PCA37PS-1.5P (1.5m)

**Accessories**

■ Accessories (Option)

- Screw terminal : EPD-37A \*1
  - Screw terminal (Screw Up type) : EPD-37 \*1
  - Terminal unit for solderless terminal (M3) : DTP-3(PC)
  - Terminal unit for leads : DTP-4(PC)
- \*1 Option cable PCB37P or PCB37PS is required separately.

\* Check the CONTEC's Web site for more information on these options.

## specification

Item	Specification
<b>Counter Input</b>	
Number of Channels	4 Channels
Count system	Up/down counting
Max. count	FFFFFFH (binary data)
Counter input type	Photo coupler isolated input or TTL-level input
Counter input signal	Phase-A/UP 1 x 4 channels Phase-B/DOWN 1 x 4 channels Phase-Z/CLR 1 x 4 channels General-purpose input 1 x 4 channels
Input register	220Ω (photo coupler insulation) or more, TTL loading (TTL-level)
Input protection circuit	None
Response frequency	Photo coupler isolated input 500KHz duty 50% (Max.) TTL-level input 1MHz duty 50% (Max.)
Interrupt level	One interrupt caused upon channel count match or timer time-out
External power	5V · 12VDC ±10% Min. 400mA (Required for photo coupler isolated input)
Photo coupler input current	Photo coupler primary current 15 · 25mA
Digital filter	0.1μsec · 1056.1μsec (can be independently set for each channel.)
Timer	1msec · 200sec
<b>Match signal output</b>	
Output point	1 x 4 channels
Output type	Photo coupler isolated open collector output
Output rating	35VDC, 50mA(Max.) (per 1 point)
Output signal width	0 · 104.45msec (All channels)
Output protection circuit	None
External power	5V · 12VDC±10%
<b>Common</b>	
I/O address	8 bits x 32 ports boundary
Power consumption	5VDC 250mA Max.
Operating condition	0 · 50°C, 10 · 90%RH (No condensation)
PCI bus specification	32bit, 33MHz, Universal key shapes supported *1
Dimension (mm)	176.41(L) x 105.68(H)
Weight	130g

\*1 This board requires power supply at +5V from an expansion slot  
(it does not work on a machine with a +3.3V power supply alone).

### Board Dimensions

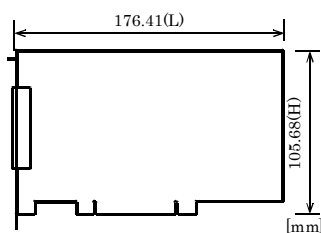

The standard outside dimension (L) is the distance from the end of the board to the outer surface of the slot cover.

## Support Software

You should use CONTEC support software according to your purpose and development environment.

### Driver Library API-PAC(W32) (Bundled)

API-PAC(W32) is the library software that provides the commands for CONTEC hardware products in the form of Windows standard Win32 API functions (DLL). It makes it easy to create high-speed application software taking advantage of the CONTEC hardware using various programming languages that support Win32 API functions, such as Visual Basic and Visual C/C++.

It can also be used by the installed diagnosis program to check hardware operations.

CONTEC provides download services (at <http://www.contec.com/apipac/>) to supply the updated drivers and differential files.

For details, read Help on the bundled CD-ROM or visit the CONTEC's Web site.

< Operating environment >

OS Windows XP, 2000, NT, Me, 98, etc..  
Adaptation language Visual C/C++, Visual Basic, Delphi, Builder, etc..

Others Each piece of library software requires 50 MB of free hard disk space.

### Linux version of general-purpose COUNT driver: API-CNT(LNX) (Supplied within the same CD-ROM of API-PAC (W32))

This driver is used to control CONTEC counter boards (PC Cards). You can control CONTEC counter boards easily using the shared library used by gcc, Kylix, the device driver (module) for each kernel version, and the board (PC Cards) configuration program (config). CONTEC provides download services (at <http://www.contec.co.jp/enom/apipac/>) to supply the updated drivers and differential files. For details, read Help on the bundled CD-ROM or visit the CONTEC's Web site.

< Operating environment >

OS RedHatLinux, TurboLinux, etc..  
(For details on supported distributions, refer to Help available after installation.)

Adaptation language gcc, Kylix  
Others Each piece of library software requires 3 MB of free hard disk space.

### Data acquisition VI library for LabVIEW VI-DAQ (Free download)

This is a VI library to use in National Instruments LabVIEW. VI-DAQ is created with a function form similar to that of LabVIEW's Data Acquisition VI, allowing you to use various devices without complicated settings.

See <http://www.contec.com/vidaq/> for details and download of VI-DAQ.

## Using the On-Board Connectors

### ◆ Connecting a Board to a Connector

To input external pulse signals, use the interface connector on the board.

Use CN1 for the photo coupler isolated input. For TTL level input, connect CN2 to an external device by connecting the optional cable CN2. Matched pulse output is output from CN1. (Photo coupler isolated open collector output)

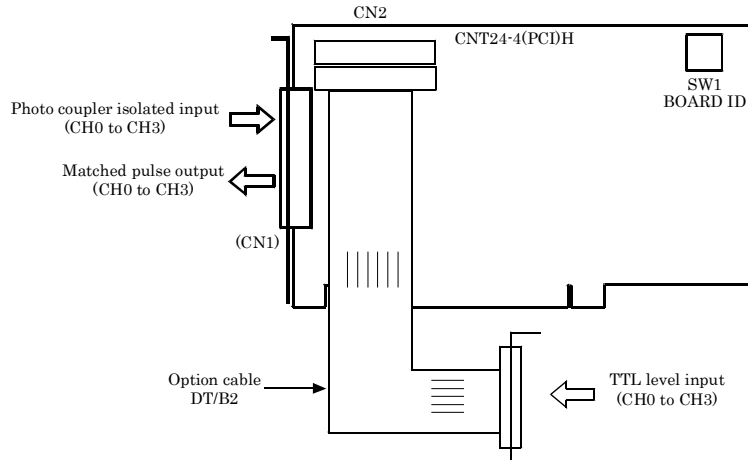

### ◆ Interface Connector Signal Assignment

Use the on-board connector to connect the interface board to an external device.

### ■ Interface connector for the photo coupler isolated input(CN1)

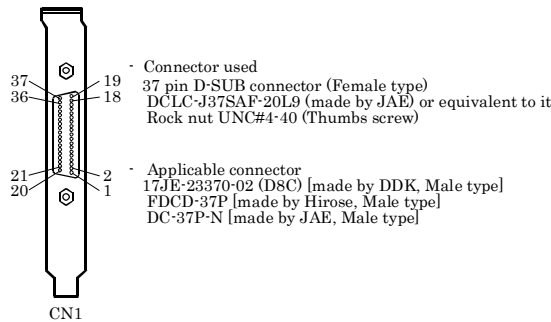

### ■ Pin Assignment of an interface connector(CN1)

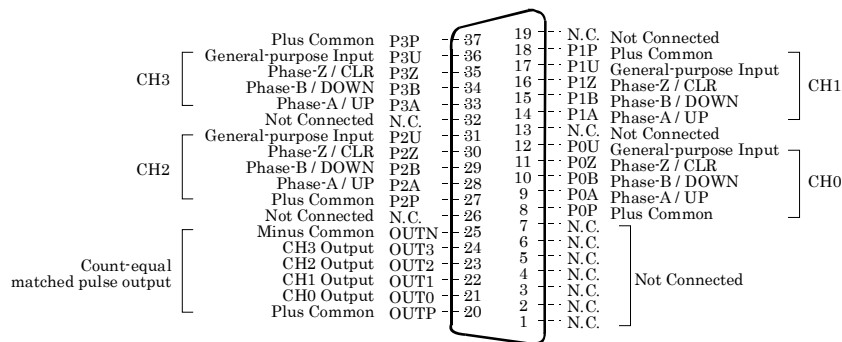

Each channel has an independent plus common. (Same for match output)

■ Interface connector for the TTL-level input(CN2)

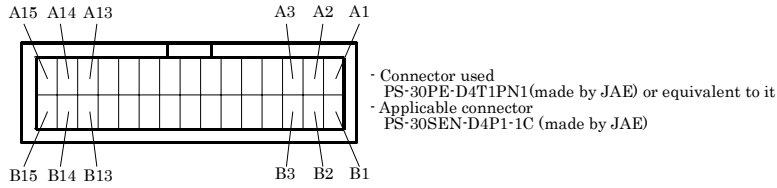

Pin Assignment of an interface connector(CN2)

CH1	Not Connected	N.C.	- A1	B1	- T0A	Phase-A / UP	CH0
	General-purpose Input	T1U	- A2	B2	- N.C.	Not Connected	
	Phase-Z / CLR	T1Z	- A3	B3	- GND*1	Ground	
	Phase-B / DOWN	T1B	- A4	B4	- GND*1	Ground	
	Phase-A / UP	T1A	- A5	B5	- GND*1	Ground	
CH0	Ground	GND*1	- A6	B6	- GND*1	Ground	CH3
	General-purpose Input	T0U	- A7	B7	- GND*1	Ground	
	Phase-Z / CLR	T0Z	- A8	B8	- GND*1	Ground	
	Phase-B / DOWN	T0B	- A9	B9	- GND*1	Ground	
	Not Connected	N.C.	- A10	B10	- T3A	Phase-A / UP	
CH3	General-purpose Input	T3U	- A11	B11	- GND*1	Ground	CH2
	Phase-Z / CLR	T3Z	- A12	B12	- T2U	General-purpose Input	
	Phase-B / DOWN	T3B	- A13	B13	- T2Z	Phase-Z / CLR	
CH2	Phase-A / UP	T2A	- A14	B14	- T2B	Phase-B / DOWN	
	+5V*2	Vcc*1	- A15	B15	- Vcc*1	+5V*2	

\*1: The VCC and GND signals are all common.  
 \*2: Outputs +5V power supplied from the +5V pin in the PC to the external device.  
 The maximum current flowing through these two Vcc pins together is 500mA.  
 Use this pin to supply +5V power to an external device (such as an encoder) for simple checking.

Optional Cable DT/B2

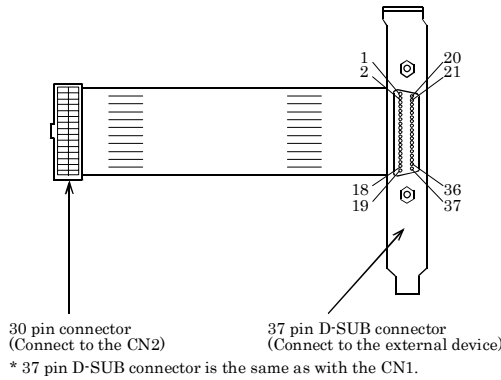

Pin Assignments of an optional cable 37-Pin D-SUB

Ground	GND*1	- 1	20	- Vcc*1	+5V*2	Not Connected	
	GND*1	- 2	21	- Vcc*1	+5V*2		
	GND*1	- 3	22	- N.C.			
	GND*1	- 4	23	- N.C.			
	GND*1	- 5	24	- N.C.			
	GND*1	- 6	25	- N.C.			
	GND*1	- 7	26	- N.C.			
CH0	Not Connected	N.C.	- 8	27	- N.C.	CH2	
	Phase-A / UP	T0A	- 9	28	- T2A		Phase-A / UP
	Phase-B / DOWN	T0B	- 10	29	- T2B		Phase-B / DOWN
	Phase-Z / CLR	T0Z	- 11	30	- T2Z		Phase-Z / CLR
	General-purpose Input	T0U	- 12	31	- T2U		General-purpose Input
CH1	Ground	GND*1	- 13	32	- GND*1	Ground	CH3
	Phase-A / UP	T1A	- 14	33	- T3A	Phase-A / UP	
	Phase-B / DOWN	T1B	- 15	34	- T3B	Phase-B / DOWN	
	Phase-Z / CLR	T1Z	- 16	35	- T3Z	Phase-Z / CLR	
	General-purpose Input	T1U	- 17	36	- T3U	General-purpose Input	
Not Connected	N.C.	- 18	37	- N.C.	Not Connected		
Not Connected	N.C.	- 19					

\*1: The VCC and GND signals are all common.  
 \*2: Outputs +5V power supplied from the +5V pin in the PC to the external device.  
 The maximum current flowing through these two Vcc pins together is 500mA.  
 Use this pin as +5V power supply to an external device (such as an encoder) for simple checking.

**Connection Method to the External device 1 -Photo coupler isolated Input-**

**◆ Photo coupler isolated Input Connection**

Photo coupler isolated input connection with a rotary encoder or a linear scale open collector output circuit is shown in the Figure. The maximum input frequency is 500KHz.

For a two-phase input, connect both phase A and phase B. For a single phase input, connect to either phase A or phase B. If not using the Z phase, this does not need to be connected.

**◆ Photo coupler Isolated Input Circuit**

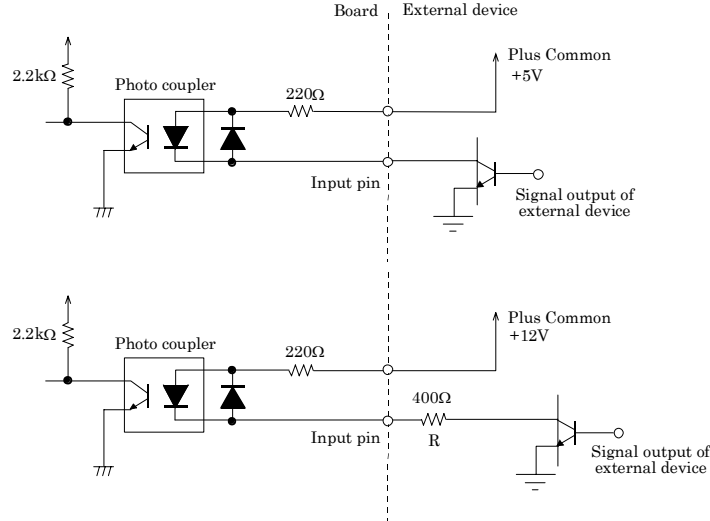

**▼ CAUTION**

- The general input signal uses the same circuit structure.
- To use external power (other than 5V); insert a current limiting resistor at the R position.

The following expression is used to calculate current limiting resistance R with the external power supply as PV:

$$\frac{P-5}{20} < Rk\Omega < \frac{P-5}{15}$$

If P=12, use a 350 < R < 470 resistor.

**Connection Method to the External device 2 -TTL-Level Input-**

**◆ TTL-Level Input Connection**

Use the TTL-Level Input for the connection with a rotary encoder or a linear scale TTL-level output circuit. The maximum input frequency is 1MHz.

For a two-phase input, connect both phase A and phase B. For a single phase input, connect to either phase A or phase B. If not using the phase Z, this does not need to be connected.

**◆ TTL-Level Input Circuit**

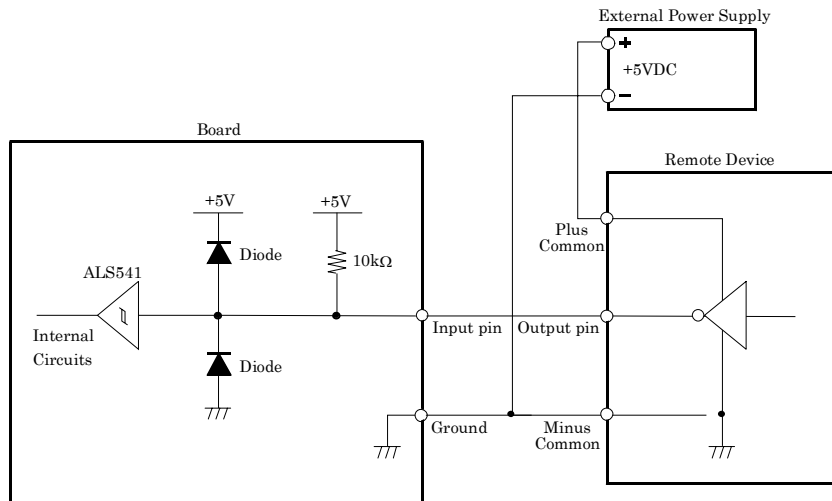

**▼ CAUTION**

- The general input signal uses the same circuit structure.
- The cable should be 1.5m or less.
- To prevent malfunction caused by noise, separate the circuit as much as possible from other signal cables and noise sources.

## One-shot Pulse Output Connection

### ◆ One-shot Pulse Output Connection

When the count value of each channel and the user set value match, the circuit outputs a matched signal for one shot (1 pulse). The signal output part uses the open collector method by photo coupler insulation. As a result, an external power supply is needed to run the board output.

### ◆ Output Circuit and an Example Connection

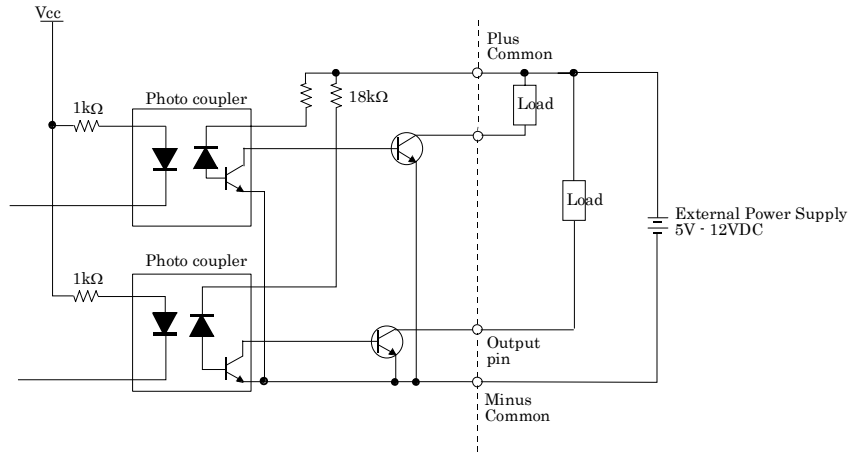

### ▼ CAUTION

The output of this board has no surge voltage protector. To drive an inductive load such as a relay or lamp using this board, apply surge voltage protection to the load side. For surge voltage protection, see "Surge Voltage Countermeasures" in the next section.

## Block Diagram

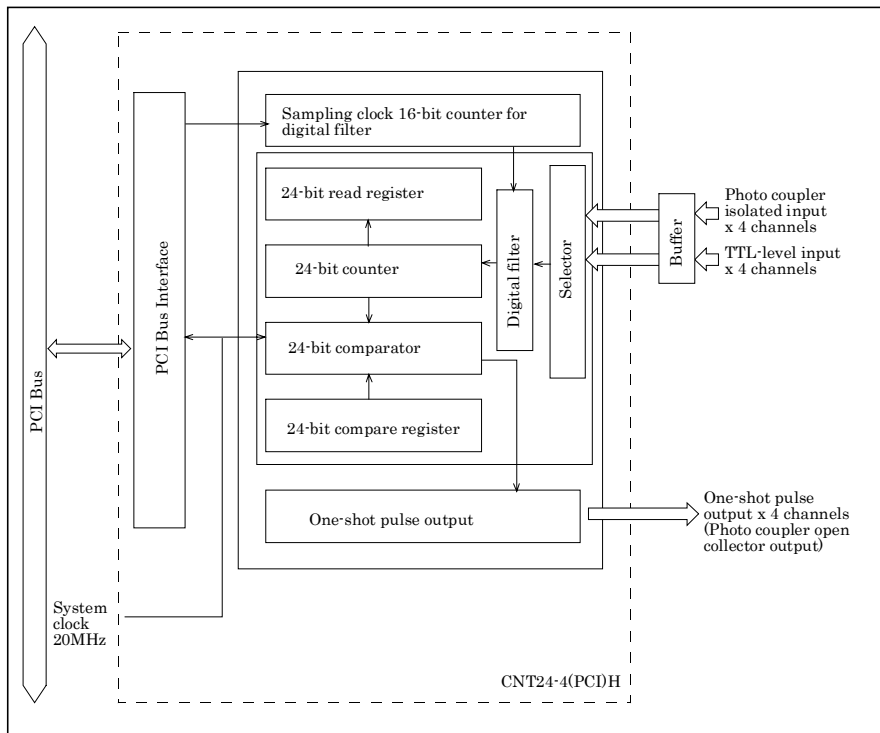

## Differences between the CNT24-4(PCDH) and CNT24-4(PCI)

The CNT24-4(PCDH) is a partially enhanced version of the conventional products of CNT24-4(PCI) and it is upper compatible with CNT24-4(PCI). There are some differences in specifications as shown below.

	CNT24-4(PCI)	CNT24-4(PCDH)
I/O address	8 bits x 4 ports boundary	8 bits x 32 ports boundary
Power consumption	5VDC 400mA (Max.)	5VDC 250mA (Max.)
PCI bus specification	32bit, 33MHz, 5V	32bit, 33MHz, Universal key shapes supported (Supply 5V to the 5V pin)
Interrupt signal resource setting	Set to select whether to use jumper JP1	Automatically set by PC
Dimension (mm)	121.69(L) x 106.68(H)	121.69(L) x 105.68(H)

The specification, color, and design of a product may be changed without a preliminary announcement.