

## MODEL GMPID – GRAPHITE™ SERIES PID MODULES

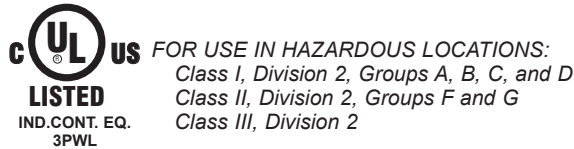

- DEDICATED SINGLE AND DUAL PID MODULES FOR THE GRAPHITE SERIES
- FULLY ISOLATED DESIGN PROVIDES RELIABLE OPERATION
- PID CONTROL WITH REDUCED OVERSHOOT
- UNIVERSAL INPUTS ACCEPT TC, RTD, 0-10 V and 0/4-20 mA SIGNALS
- ON DEMAND AUTO-TUNING OF PID SETTINGS
- DC ANALOG OUTPUT (OPTIONAL, GMP1 ONLY)
- HEATER CURRENT INPUT (OPTIONAL) ENSURES DETECTION OF HEATER CIRCUIT FAILURE
- WINDOWS® CONFIGURATION SOFTWARE



For Model No. GMP1SA00, GMP1SM00, GMP2S000, and GMP2SM00 Only

For Model No. GMP1SA00, GMP1SM00, GMP2S000, and GMP2SM00 Only

### GENERAL DESCRIPTION

The Model GMPID series modules are full featured PID controllers designed for use with the Graphite Series. The GMP1 is a single loop controller, while the GMP2 is a dual loop controller. The design of the system provides a true modular PID control platform for multi-zone control applications. The modules can accept a wide range of thermocouple, RTD, 0-10 V, 0/4-20 mA signals. With multiple discrete outputs, plus an optional analog output (GMP1 only), the GMPID modules can perform virtually any combination of time-proportioning or linear control for heat, cool, or heat/cool applications. The discrete outputs may also be assigned to one of seven internal soft alarms. The GMP1's optional linear output can be assigned to transmit virtually any internal variable.

The modules connect and communicate via proprietary USB connection to the various Graphite host devices. The Graphite host devices, equipped with serial ports as well as an Ethernet port(s), allows the system to share data with PCs, PLCs, and SCADA systems. The maximum number of modules varies for each Graphite host device, see specific models for details.

Once programmed, the module will continue to operate/control independent of the Graphite host device as long as power is applied. Remove power from the host device before installing or replacing any modules.

The GMPID modules are available with various discrete output combinations, including relays, and open drain MOSFETs. For applications requiring large loads to be controlled, several DIN rail mount relays are available.

The modules can operate in On/Off, P, PI, or PID control mode, and use an on-demand Auto-Tune that establishes the tuning constants. The PID constants may be fine-tuned through the serial or Ethernet interface. The modules employ a unique overshoot suppression feature, which allows the quickest response without excessive overshoot. The modules can also be operated in manual mode, providing the operator with direct control of the output.

### CONFIGURATION

The Graphite Series is configured with Windows® compatible Crimson® software. The software is an easy to use, graphical interface which provides a means of communication configuration, as well as commissioning and calibration of new systems.

### ALARMS

Each loop within the modules has seven internal “soft” alarms, which can be assigned to trigger any output. This includes four process alarms, two heater current, and one input fault alarm.

### ANALOG OUTPUT OPTION (GMP1 ONLY)

The optional DC Analog Output (10 V or 20 mA) can be independently configured and scaled for control or re-transmission purposes.

### HEATER CURRENT MONITOR OPTION

The optional Heater Current Monitor input is useful for early warning of heater degradation, or heater circuit failure. The input connects to a current transformer with an output of 100 mA AC to ensure that proper heater current is present when the control output is on, and that little or no current is present when the output is off. This provides immediate warning of a circuit short or open, instead of waiting for a high or low temperature shutdown alarm.

 **WARNING - EXPLOSION HAZARD - DO NOT DISCONNECT EQUIPMENT UNLESS POWER HAS BEEN SWITCHED OFF OR AREA IS KNOWN TO BE NON-HAZARDOUS.**

 **WARNING - EXPLOSION HAZARD - SUBSTITUTION OF COMPONENTS MAY IMPAIR SUITABILITY FOR CLASS I, DIVISION 2**

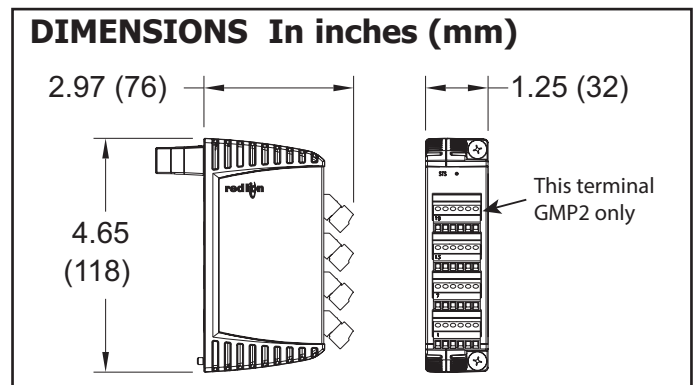

## SAFETY SUMMARY

All safety related regulations, local codes and instructions that appear in the manual or on equipment must be observed to ensure personal safety and to prevent damage to either the instrument or equipment connected to it. If equipment is used in a manner not specified by the manufacturer, the protection provided by the equipment may be impaired.

Do not use the controller to directly command motors, valves, or other actuators not equipped with safeguards. To do so can be potentially harmful to persons or equipment in the event of a fault to the controller. An independent and redundant temperature limit indicator with alarm outputs is strongly recommended.

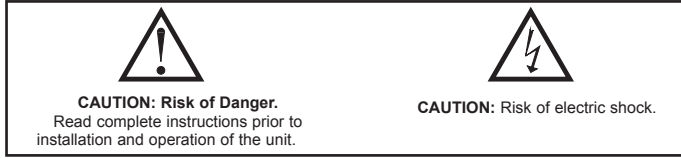

## SPECIFICATIONS

1. **POWER:** Power will be supplied by the Graphite host device. Some modules, depending on usage may consume high levels of power. This may limit the total number of modules that can be installed on a single Graphite host. Check the Graphite module and Graphite host data sheets for specific usage and power requirements.

GMPID1 Max Power: 3.3 W

GMPID2 Max Power: 2.7 W

2. **LEDs\*:**

**STS** - Status LED shows module condition

**OP1, OP2, OP3, OP4** - Indicate status of outputs 1, 2, 3, and 4

**ALM**, or **AL1** and **AL2** - Alarm LEDs are lit during any internal alarm condition

\* Default configuration.

3. **MEMORY:** Non-volatile memory retains all programmable parameters.

4. **INPUT:**

**GENERAL:**

Sample Time: 50 msec (20 Hz)

Common Mode Rejection: >110 dB, 50/60 Hz

Normal Mode Rejection: >50 dB, 50/60 Hz

Temperature Coefficient: 0.01%/°C

Step Response Time: 100 msec typ., 200 msec max

**THERMOCOUPLE INPUTS:**

Types: T, E, J, K, R, S, B, N, C

Input Impedance: 20 MΩ

Lead Resistance Effect: 0.25 μV/Ω

Cold Junction Compensation: Less than ±1°C typical (±1.5°C max) over -40 to 75 °C ambient temperature

Resolution: 0.1°

TYPE	MEASUREMENT RANGE	WIRE COLOR	
		ANSI	BS 1843
T	-200 to +400°C -328 to +752°F	(+) Blue (-) Red	(+) White (-) Blue
E	-200 to +730°C -328 to +1346°F	(+) Violet (-) Red	(+) Brown (-) Blue
J	-200 to +760°C -328 to +1400°F	(+) White (-) Red	(+) Yellow (-) Blue
K	-200 to +1350°C -328 to +2462°F	(+) Yellow (-) Red	(+) Brown (-) Blue
R	0 to +1768°C +32 to +3214°F	No Standard	(+) White (-) Blue
S	0 to +1768°C +32 to +3214°F	No Standard	(+) White (-) Blue
B	+149 to +1820°C +300 to +3308°F	No Standard	No Standard
N	-200 to +1300°C -328 to +2372°F	(+) Orange (-) Red	(+) Orange (-) Blue
C	0 to +2315°C +32 to +4199°F	No Standard	No Standard
W5/W6	0 to +2315°C +32 to +4199°F	No Standard	No Standard
mV	0 mV to 50 mV	N/A	N/A

**RTD INPUTS:**

Type: 2 or 3 wire

Excitation: 150 μA

Lead Resistance: 15 Ω Max

Resolution: 1 or 0.1°

TYPE	INPUT TYPE	RANGE
385	100 Ω platinum, Alpha = .00385	-200 to +600°C -328 to +1100°F
392	100 Ω platinum, Alpha = .003919	-200 to +600°C -328 to +1100°F
672	120 Ω nickel, Alpha = .00672	-80 to +215°C -112 to +419°F

**PROCESS INPUT:**

INPUT RANGE	ACCURACY	IMPEDANCE	MAX CONTINUOUS OVERLOAD	RESOLUTION
10 V	0.1% span	1 M Ohm	50 V	16 bit
20 mA	0.1% span	10 Ohm	100 mA	16 bit

5. **PROBE BREAK RESPONSE:** Upscale drive, Input Fault Alarm bit set high, ALx LED illuminates.

6. **TEMPERATURE INDICATION ACCURACY:** ± (0.3% of span, +1°C). Includes NIST conformity, cold junction effect, A/D conversion errors, temperature coefficient and linearization conformity at 23 °C after 20 minute warm up.

7. **ISOLATION LEVEL:** 500 Vrms @ 50/60 Hz for 1 minute between the following:

OP1

OP2

OP3

OP4

Linear Output (GMP1 only)

Signal Input 1 and HCM

Signal Input 2 and HCM (GMP2 only)

Power Supply Input

8. **COMMUNICATIONS:** Provided by the graphite host device

9. **A/D CONVERTER:** 16 bit resolution

10. **DISCRETE OUTPUTS:**

**GMP1:** Outputs 1 and 2 available as Solid State NFET or Form A relay.

Output 3 is an SSR NFET or Form C relay.

**GMP2:** Outputs 1 through 4 available as Form A relay or Solid State NFET.

**Solid State Output:**

Type: Switched DC, N Channel open drain MOSFET

Current Rating: 1 A max

VDS ON: 0.3 V @ 1 A

VDS MAX: 30 VDC

Offstate Leakage Current: 0.5 mA max

**Form A Relay Output:**

Type: N.O.

Current Rating: 3 Amps @ 125 VAC or 30 VDC (resistive load)

1/10 HP @ 125 VAC

Life Expectancy: 200,000 cycles at maximum load rating. (Decreasing load, increasing cycle time, and use of surge suppression such as RC snubbers increases life expectancy.)

**Form C Relay Output:**

Type: SPDT

Current Rating: 5 Amps @ 125 VAC or 28 VDC (resistive load)

1/8 HP @ 125 VAC

Life Expectancy: 100,000 cycles at maximum load rating. (Decreasing load, increasing cycle time, and use of surge suppression such as RC snubbers increases life expectancy.)

11. **CONTROL MODES:**

Control: On/Off, P, PI, or PID

Output: Time proportioning or linear (GMP1 only)

Cycle Time: Programmable from 0.0 to 60.0 sec

Auto-Tune: When selected, sets proportional band, integral time, derivative time values, and output dampening time

Probe Break Action: Programmable response

Sensor Fail Response: Upscale

12. **ALARMS:**

Modes:

Manual

Absolute High Acting

Absolute Low Acting

Deviation High Acting

Deviation Low Acting

Inside Band Acting

Outside Band Acting

Reset Action: Programmable; automatic or latched

Standby Mode: Programmable; enable or disable

Hysteresis: Programmable

Sensor Fail Response: Upscale

13. **ANALOG DC OUTPUT** (optional, GMP1 only):  
 Selectable/programmable for 0-10 VDC, 0-20 mA, or 4-20 mA  
 Resolution:  
 Voltage: 500  $\mu$ V  
 Current: 1  $\mu$ A  
 Accuracy:  
 0.1% of full scale (18 to 28 °C)  
 0.2% of full scale (-40 to 75 °C)  
 Update Time: 0.0 to 60.0 sec  
 Compliance (for current output only): 500  $\Omega$  max.  
 Minimum load (voltage output only): 10 K $\Omega$  min.  
 Outputs are software selectable for either 10 V or 20 mA. The output range may be field calibrated to yield approximate 10% overrange and a small underrange (negative) signal.
14. **HEATER CURRENT MONITOR INPUT** (optional):  
 Type: 300 V max, 50 A max. Single phase, full wave monitoring of load currents  
 Input: 100 mA max. input for use with external current transformers  
 Input Resistance: 5  $\Omega$   
 Accuracy:  $\pm$ 3.0% full scale, 5 to 100% of range  
 Frequency: 50 to 400 Hz  
 Minimum output on time for break alarm: 350 msec  
*Note: To ensure isolation to SELV circuits, use a UL Listed current transformer.*
15. **ENVIRONMENTAL CONDITIONS:**  
 Operating Temperature Range: Limited to host  
 Storage Temperature Range: -40 to +85 °C  
 Shock to IEC 68-2-27: Operational 40 g (10 g, modules w/relays)  
 Operating and Storage Humidity: 85% max relative humidity, non-condensing, from 0 to +50°C  
 Altitude: Up to 2000 meters

16. **CERTIFICATIONS AND COMPLIANCES:**  
**CE Approved**  
 EN 61326-1 to Industrial Locations  
 IEC/EN 61010-1  
 RoHS Compliant  
**ATEX Approved** (GMP1SA00, GMP1SM00, GMP2S000, and GMP2SM00 only)  
 II 3 G Ex nA IIC T4 Gc  
 II 3 D Ex tc IIIC T135°C Dc  
 DEMKO 14 ATEX 1387X  
 EN 60079-0, -15, -31  
**IECEx Approved** (GMP1SA00, GMP1SM00, GMP2S000, and GMP2SM00 only)  
 Ex nA IIC T4 Gc  
 Ex tc IIIC T135°C Dc  
 IECEx UL 15.0035X  
 IEC 60079-0, -15, -31  
 UL Listed: File #E302106  
 UL Hazardous (GMP1SA00, GMP1SM00, GMP2S000, and GMP2SM00 only): File #E317425
17. **CONSTRUCTION:** Case body is all metal construction. For indoor use only. Installation Category II, Pollution Degree 2.
18. **CONNECTIONS:** Removable wire clamp screw terminal blocks.  
 Wire Gage: 28-16 AWG (0.32 mm - 1.29 mm) terminal gage wire  
 Torque: 1.95-2.21 inch-lbs (0.22-0.25 N-m)
19. **MOUNTING:** Screws to host.
20. **WEIGHT:** GMP1: 8 oz (224 g)  
 GMP2: 8 oz (224 g)

## BLOCK DIAGRAM

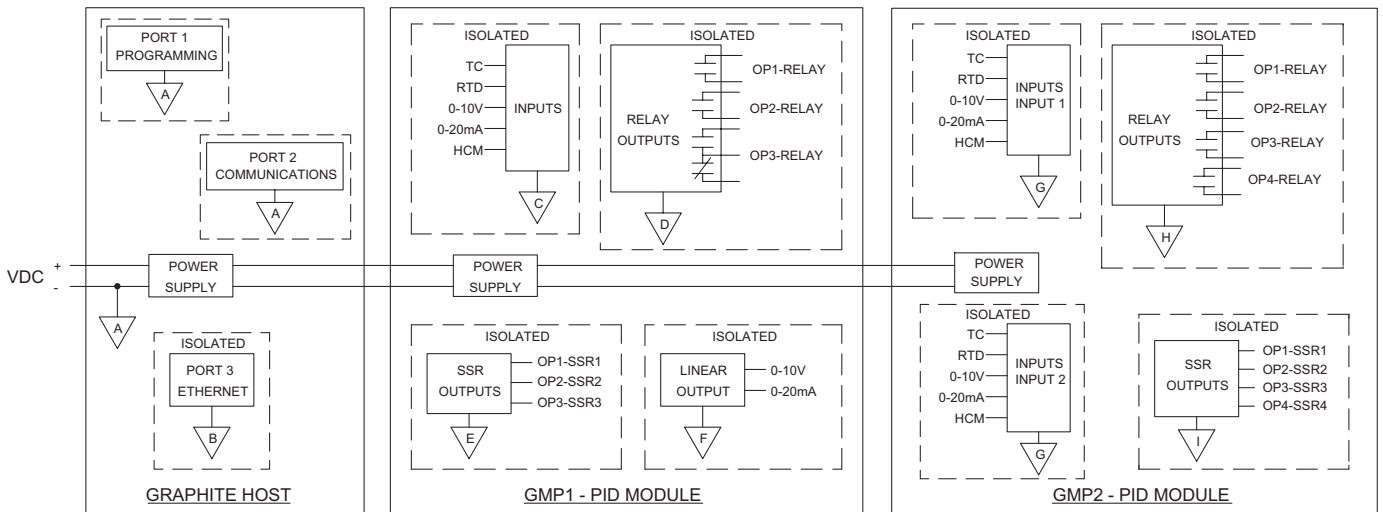

## EMC INSTALLATION GUIDELINES

Although Red Lion Controls Products are designed with a high degree of immunity to Electromagnetic Interference (EMI), proper installation and wiring methods must be followed to ensure compatibility in each application. The type of the electrical noise, source or coupling method into a unit may be different for various installations. Cable length, routing, and shield termination are very important and can mean the difference between a successful or troublesome installation. Listed are some EMI guidelines for a successful installation in an industrial environment.

1. A unit should be mounted in a metal enclosure, which is properly connected to protective earth.
2. Use shielded cables for all Signal and Control inputs. The shield connection should be made as short as possible. The connection point for the shield depends somewhat upon the application. Listed below are the recommended methods of connecting the shield, in order of their effectiveness.
  - a. Connect the shield to earth ground (protective earth) at one end where the unit is mounted.
  - b. Connect the shield to earth ground at both ends of the cable, usually when the noise source frequency is over 1 MHz.
3. Never run Signal or Control cables in the same conduit or raceway with AC power lines, conductors, feeding motors, solenoids, SCR controls, and heaters, etc. The cables should be run through metal conduit that is properly grounded. This is especially useful in applications where cable runs are long and portable two-way radios are used in close proximity or if the installation is near a commercial radio transmitter. Also, Signal or Control cables within an enclosure should be routed as far away as possible from contactors, control relays, transformers, and other noisy components.
4. Long cable runs are more susceptible to EMI pickup than short cable runs.
5. In extremely high EMI environments, the use of external EMI suppression devices such as Ferrite Suppression Cores for signal and control cables is

effective. The following EMI suppression devices (or equivalent) are recommended:

Fair-Rite part number 0443167251 (RLC part number FCOR0000)

Line Filters for input power cables:

Schaffner # FN2010-1/07 (Red Lion Controls # LFIL0000)

6. To protect relay contacts that control inductive loads and to minimize radiated and conducted noise (EMI), some type of contact protection network is normally installed across the load, the contacts or both. The most effective location is across the load.
  - a. Using a snubber, which is a resistor-capacitor (RC) network or metal oxide varistor (MOV) across an AC inductive load is very effective at reducing EMI and increasing relay contact life.
  - b. If a DC inductive load (such as a DC relay coil) is controlled by a transistor switch, care must be taken not to exceed the breakdown voltage of the transistor when the load is switched. One of the most effective ways is to place a diode across the inductive load. Most RLC products with solid state outputs have internal zener diode protection. However external diode protection at the load is always a good design practice to limit EMI. Although the use of a snubber or varistor could be used.  
RLC part numbers: Snubber: SNUB0000  
Varistor: ILS11500 or ILS23000
7. Care should be taken when connecting input and output devices to the instrument. When a separate input and output common is provided, they should not be mixed. Therefore a sensor common should NOT be connected to an output common. This would cause EMI on the sensitive input common, which could affect the instrument's operation.

Visit RLC's web site at <http://www.redlion.net/emi> for more information on EMI guidelines, Safety and CE issues as they relate to Red Lion Controls products.

## HARDWARE INSTALLATION

Modules must be installed beginning with slot 1 (left-most slot), with no empty slots between the modules, and the order must match the modules order in Crimson. Torque screws to 6.0 pound-force inch [96 ounce-force inch] (0.68 Nm).

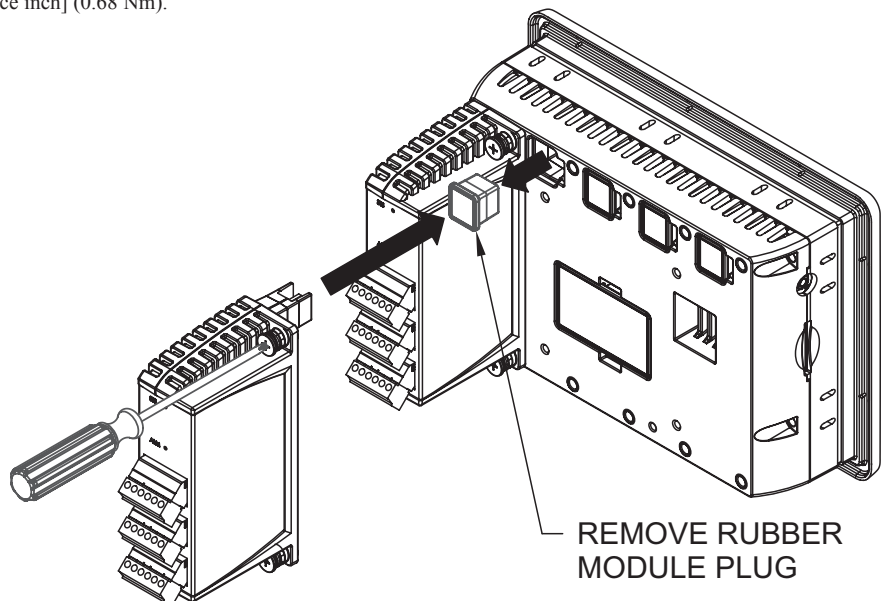
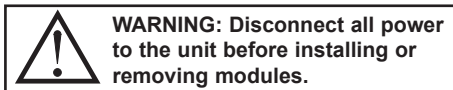

# WIRING

## WIRING CONNECTIONS

All conductors should meet voltage and current ratings for each terminal. Also, cabling should conform to appropriate standards of good installation, local codes and regulations and be suitably rated for the temperatures of the environment to which it is being installed. When wiring the module, use the numbers on the label to identify the position number with the proper function. Strip the wire, leaving approximately 1/4" (6 mm) of bare wire exposed. Insert the wire into the terminal, and tighten.

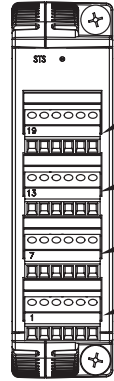

Terminals 19 to 24  
(GMP2 Only)

Terminals 13 to 18

Terminals 7 to 12

Terminals 1 to 6



**WARNING - EXPLOSION HAZARD - DO NOT CONNECT OR DISCONNECT CABLES WHILE POWER IS APPLIED UNLESS AREA IS KNOWN TO BE NON-HAZARDOUS.**

## GMP1 INPUT CONNECTIONS

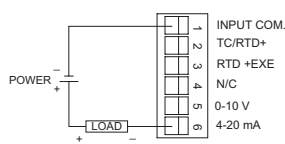
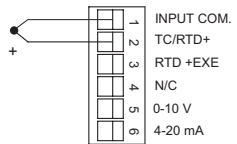
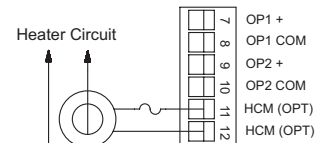
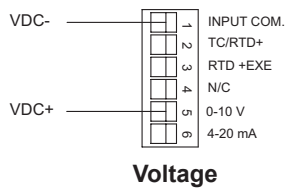
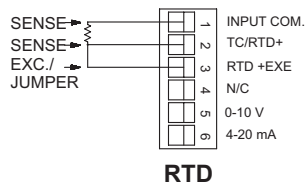

Thermocouple and Millivolt

Current

## GMP2 INPUT CONNECTIONS

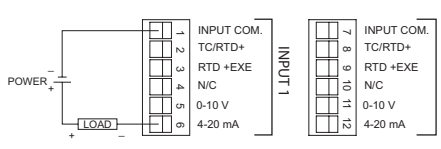
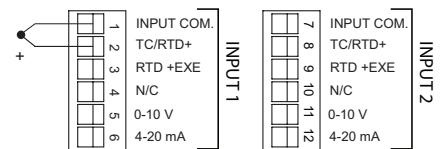
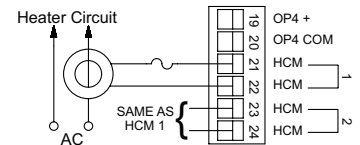
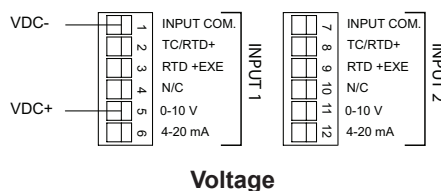
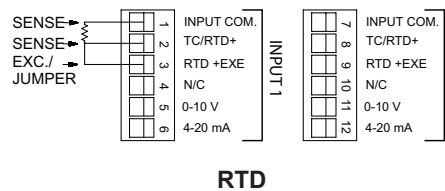

Thermocouple and Millivolt

Current

## GMP1 OUTPUT CONNECTIONS

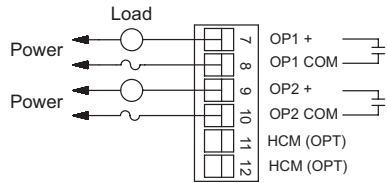

Outputs 1 and 2 - Relay Version

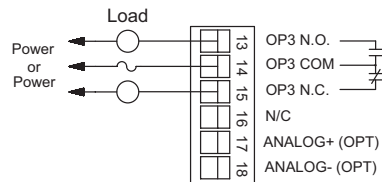

Output 3 - Relay Version

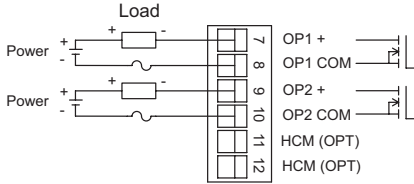

Outputs 1 and 2 - Solid State Version

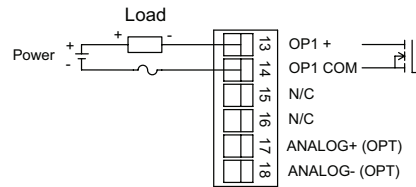

Output 3 - Solid State Version

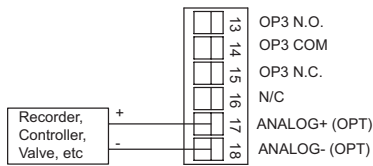

Analog Output

## GMP2 OUTPUT CONNECTIONS

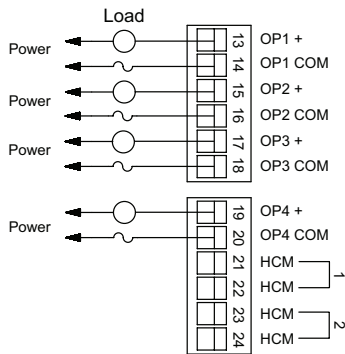

Outputs 1- 4 - Relay Version

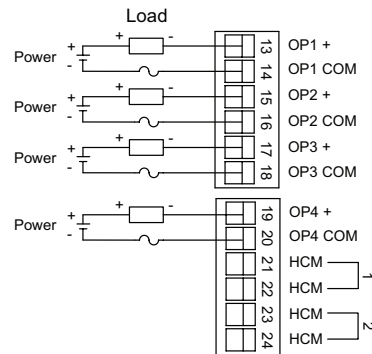

Outputs 1- 4 - Solid State Version

## LEDS

### STS – STATUS LED

The Status LED is a green LED that provides information regarding the state of the module. This includes indication of the various stages of the start-up routine (power-up), as well as any errors that may occur.

#### Startup Routine

Off	Module is currently running the boot loader and/or being flash upgraded by Crimson.
Flashing Green	Module switching to configuration.
Green	Module performing normally.

#### Error States

Flashing Green	Module is controlling properly, but has lost communication with the Host.
----------------	---

### OP1, OP2, OP3, OP4\* – OUTPUT STATUS LED

The OP1, OP2, OP3, and OP4\* LEDs are factory configured to indicate the status of the outputs. The LEDs turn on when the output is active.

These LEDs may be remapped to various other module properties.

\*GMP2 only

### ALM OR AL1 & AL2 – ALARM LED

The Alarm LEDs are factory configured to indicate the presence of an alarm. Whenever one of the seven alarms is active, the LED turns on.

These LEDs may be remapped to various other module properties.

### FIRMWARE UPGRADE

The module's firmware is stored in flash memory so that software/hardware conflicts are avoided, and so features can be added in the future.

During a download, Crimson compares its own library of firmware files with those stored in the module. If they do not match, Crimson will download the necessary firmware.

### CONFIGURATION

Programming is done via Crimson® software, a Windows® compatible configuration interface. Please see the Crimson manual for more information.

---

## ORDERING INFORMATION

TYPE	DESCRIPTION	PART NUMBER
Operator Interface Panels	Graphite 7" Color Touch Screen, Indoor, 24 VDC Powered	G07C0000
	Graphite 7" Color Touch Screen, Indoor/Outdoor, 24 VDC Powered	G07S0000
	Graphite 9" Color Touch Screen, Indoor, 24 VDC Powered	G09C0000
	Graphite 9" Color Touch Screen, Indoor, 24 VDC Powered, Additional Ethernet Port	G09C1000
	Graphite 10" Color Touch Screen, Indoor, 24 VDC Powered	G10C0000
	Graphite 10" Color Touch Screen, Indoor, 24 VDC Powered, Additional Ethernet Port	G10C1000
	Graphite 10" High Resolution Display, Color Touch Screen, Indoor, 24 VDC Powered	G10R0000
	Graphite 10" High Resolution Display, Color Touch Screen, Indoor, 24 VDC Powered, Additional Ethernet Port	G10R1000
	Graphite 10" Color Touch Screen, Indoor/Outdoor, 24 VDC Powered	G10S0000
	Graphite 10" Color Touch Screen, Indoor/Outdoor, 24 VDC Powered, Additional Ethernet Port	G10S1000
	Graphite 12" Color Touch Screen, Indoor, 24 VDC Powered	G12C0000
	Graphite 12" Color Touch Screen, Indoor, 24 VDC Powered, Additional Ethernet and Serial Port	G12C1100
	Graphite 15" Color Touch Screen, Indoor, 24 VDC Powered	G15C0000
	Graphite 15" Color Touch Screen, Indoor, 24 VDC Powered, Additional Ethernet and Serial Port	G15C1100
Input Modules	Graphite Module, Single PID, Relay and Analog Outputs	GMP1RA00
	Graphite Module, Single PID, Relay and Heater Current Monitor	GMP1RM00
	Graphite Module, Single PID, SSR and Analog Outputs	GMP1SA00
	Graphite Module, Single PID, SSR and Heater Current Monitor	GMP1SM00
	Graphite Module, Dual PID, Relay Outputs	GMP2R000
	Graphite Module, Dual PID, Relay and Heater Current Monitor	GMP2RM00
	Graphite Module, Dual PID, SSR Outputs	GMP2S000
	Graphite Module, Dual PID, SSR and Heater Current Monitor	GMP2SM00
Accessories	50 Amp Current Transformer (For Heater Current Models) UL Recognized component, Instrument Transformers, Inc. Part #2SFT500-0.1	CT005001

### **LIMITED WARRANTY**

The Company warrants the products it manufactures against defects in materials and workmanship for a period limited to two years from the date of shipment, provided the products have been stored, handled, installed, and used under proper conditions. The Company's liability under this limited warranty shall extend only to the repair or replacement of a defective product, at The Company's option. The Company disclaims all liability for any affirmation, promise or representation with respect to the products.

The customer agrees to hold Red Lion Controls harmless from, defend, and indemnify RLC against damages, claims, and expenses arising out of subsequent sales of RLC products or products containing components manufactured by RLC and based upon personal injuries, deaths, property damage, lost profits, and other matters which Buyer, its employees, or sub-contractors are or may be to any extent liable, including without limitation penalties imposed by the Consumer Product Safety Act (P.L. 92-573) and liability imposed upon any person pursuant to the Magnuson-Moss Warranty Act (P.L. 93-637), as now in effect or as amended hereafter.

No warranties expressed or implied are created with respect to The Company's products except those expressly contained herein. The Customer acknowledges the disclaimers and limitations contained herein and relies on no other warranties or affirmations.

Red Lion Controls  
Headquarters  
20 Willow Springs Circle  
York PA 17406  
Tel +1 (717) 767-6511  
Fax +1 (717) 764-0839

Red Lion Controls  
Europe  
Softwareweg 9  
NL - 3821 BN Amersfoort  
Tel +31 (0) 334 723 225  
Fax +31 (0) 334 893 793

Red Lion Controls  
India  
201-B, 2nd Floor, Park Centra  
Opp 32 Mile Stone, Sector-30  
Gurgaon-122002 Haryana, India  
Tel +91 984 487 0503

Red Lion Controls  
China  
Unit 1102, XinMao Plaza  
Building 9, No.99 Tianzhou Road  
ShangHai, P.R. China 200223  
Tel +86 21 6113 3688  
Fax +86 21 6113 3683