

NEMA 4 1/16 DIN SERIES ENCLOSURES

ENC11A & ENC11B - PLASTIC ENCLOSURES

- RUGGED POLYCARBONATE CONSTRUCTION
- COMPLETELY SEALED FOR NEMA 4X/IP65 WASH-DOWN
- EASY MOUNTING OPTIONS

DESCRIPTION

These enclosures are designed for applications requiring a water resistant instrument enclosure. The ENC11A and ENC11B enclosures are fabricated of polycarbonate and are designed to withstand NEMA 4X/IP65 wash-down applications. The enclosures must be drilled to accept conduit fittings or other types of wiring connectors. The enclosures can be used free-standing, or securely fastened to a mounting surface. The enclosures are precut for either one or two meters. When properly installed, the meter and the enclosure can withstand NEMA 4X wash-down applications.

Electrical connections to the enclosed instrument are easily made by drilling the desired location on the back or side of the enclosure. Select the proper drill size to accommodate the conduit fitting or other wire connector. To maintain the enclosure NEMA 4X rating, sealed connectors must be used. Also enclosed are wall fastening lugs, which can be used to easy mount the enclosure to a wall.

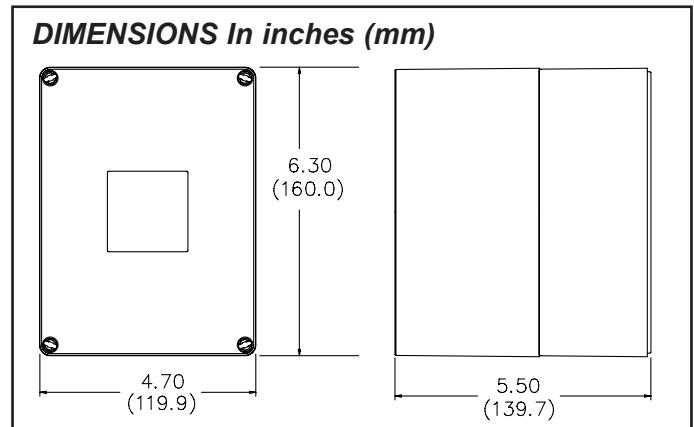

ORDERING INFORMATION

MODEL NO	DESCRIPTION	PART NUMBER
ENC11A	NEMA 4X/IP65 Enclosure for One 1/16 DIN Meter	ENC11A00
ENC11B	NEMA 4X/IP65 Enclosure for Two 1/16 DIN Meters	ENC11B00

ENC11A AND ENC11B INSTALLATION

It is recommended to wire the unit before mounting it in the enclosure to ensure good electrical connections. The following steps outline the most common sequence for installing a unit.

1. Determine the location of the conduit fitting and drill the necessary hole. Install the fitting and bring the wiring into the enclosure.
2. Slide the panel gasket over the rear of the unit to the back of the bezel.
3. Install the unit through the opening in the front of the lid until the bezel flange contacts the panel.
4. Slide the mounting clip over the rear of the unit until the mounting clip is against the inside of the enclosure. The mounting clip has latching features which engage into mating features on the unit's housing.

Note: It is necessary to hold the unit in place when sliding the mounting clip into position.

5. While holding the unit in place, push the panel latch over the rear of the unit so that the tabs of the panel latch engage in the slots on the case. The panel latch should be engaged in the farthest forward slot possible. To achieve a proper seal, tighten the latch screws evenly until the unit is snug in the panel (Torque to approximately 7 in-lbs [79 N-cm]). Do not over-tighten the screws.
6. If the gasket is not adequately compressed, and the mounting screws can no longer be turned, loosen the mounting screws and check that the mounting clip is latched as close as possible to the inside of enclosure. Repeat the procedure for tightening the screws.
7. Connect the necessary wires to the unit for the application desired.
8. Assemble the enclosure with the screws provided. Alternately tighten each screw to ensure uniform gasket pressure.

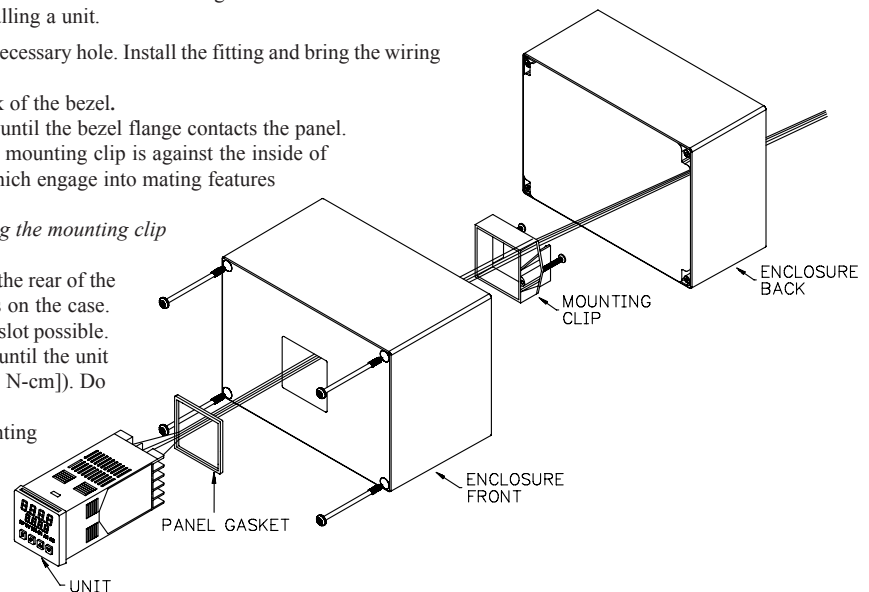

ENC11 - STEEL ENCLOSURE

- RUGGED STEEL CONSTRUCTION
- COMPLETELY SEALED FOR WASH-DOWN
- VERSATILE MOUNTING OPTIONS FOR MACHINE OR DESKTOP



DESCRIPTION

This enclosure is designed for applications requiring a water resistant instrument enclosure. The enclosure is fabricated of formed steel with all seams welded to withstand NEMA 4/IP65 wash-down applications. The kit is coated with a durable flat black polyurethane finish.

Electrical connections to the enclosed instrument are easily made through a removable access panel at the rear of the enclosure. The panel must be drilled to accept conduit fittings or other types of wiring connectors.

The enclosure can be used free-standing or securely fastened to a mounting surface with brackets which are provided with each enclosure. The brackets also allow the enclosure to be raised and/or tilted from the mounting surface in order to achieve the most favorable operating position. Self-adhering rubber pads are provided which can be applied to the bottom of the enclosure. These rubber pads will protect the mounting surface and are particularly useful for free-standing installations.

DIMENSIONS In inches (mm)

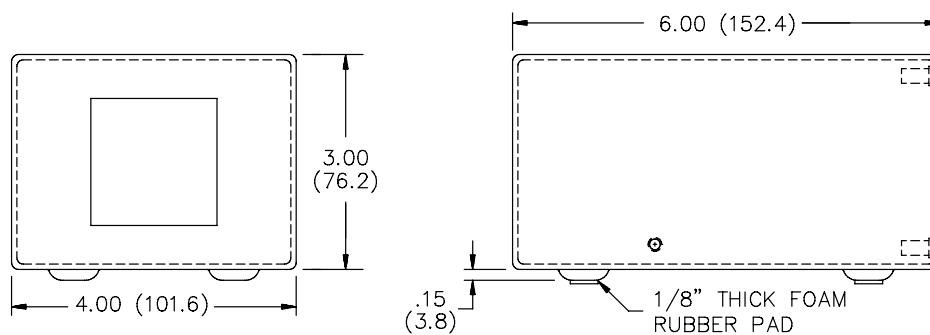

ORDERING INFORMATION

MODEL NO.	DESCRIPTION	PART NUMBER
ENC11	NEMA 4 Enclosure for 1/16 DIN Units	ENC11000

Red Lion Controls
20 Willow Springs Circle
York PA 17406
Tel +1 (717) 767-6511
Fax +1 (717) 764-0839

Red Lion Controls BV
Printerweg 10
NL - 3821 AD Amersfoort
Tel +31 (0) 334 723 225
Fax +31 (0) 334 893 793

Red Lion Controls AP
Unit 101, XinAn Plaza
Building 13, No.99 Tianzhou Road
ShangHai, P.R. China 200223
Tel +86 21 6113-3688
Fax +86 21 6113-3683