

JetNet 5010G / 5010G-w

Industrial 7+3G Gigabit Managed Ethernet Switch

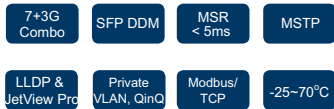

- 7 10 / 100-TX ports and 3 Gigabit RJ-45/SFP combo ports (10 / 100 / 1000 Base-T, 100 Base-FX, 1000 Base-X)
- SFP ports support 100/1000 Fiber with Digital Diagnostic Monitoring (DDM) to monitor long distance fiber quality
- Multiple Super Ring (recovery time <5ms), Rapid Dual Homing, Multiple Ring, and MSTP/RSTP
- VLAN, Private VLAN, QinQ, GVRP, QoS, IGMP Snooping V1/V2/V3, Rate Control, Port Trunking, LACP, Online Multi-Port Mirroring
- 32Gbps Non-Blocking, switch backplane 8K MAC address table
- Supports LLDP and JetViewPro i²NMS software for auto-topology visualization and efficient group management
- Supports Modbus TCP/IP for Factory Automation
- Supports console CLI , Web, SNMP V1/V2c/V3, RMON, HTTPS, SSH for remote management
- Advanced security feature supports IP Security, Port Security, DHCP Server, IP and MAC Binding, 802.1x network access control
- Event Notification by E-mail, SNMP trap, Syslog, Digital Input and Relay Output
- Dual 12-48VDC power inputs
- IP31 rugged aluminum case
- Operating temperature -25~70°C for JetNet 5010G, -40~70°C for JetNet 5010G-w

- Industrial Intelligent NMS
- Rackmount PoE Plus Switch
- Industrial PoE Plus Switch
- Industrial 12-24V PoE Switch
- Industrial PoE Switch
- Rackmount L3/L2 Switch
- Gigabit Managed Switch
- Managed Ethernet Switch
- Entry-level Switch
- Wireless Outdoor AP
- Embedded PoE/Router Computer (LINUX)
- Industrial Communication Computer (WIN/LINUX)
- Ethernet/PoE/ Serial Board
- Ethernet I/O Server
- Media Converter
- Serial Device Server
- SFP Module
- Din Rail Power Supply

Overview

The JetNet 5010G is a Managed Industrial Ethernet Switch, equipped with 7 ports 10/100TX and 3 ports 10/100/1000 RJ-45/100-FX/Gigabit SX/LX combo ports. The 2 gigabit ports are used to form the nonstop Rapid Super Ring. The 3rd gigabit port is used to connect to upper switch, to couple ring or public server. The gigabit combo port design gives the flexibility to choose copper or fiber media, 100Base-FX or 1000Base-X, multi-mode or Single-Mode for different distance application, need of without stocking different switch models. The JetNet 5010G is designed as rugged

surface in aluminum material with curvilinear heating dispersing mechanical design and wide operating temperature. The embedded software supports full Layer 2 management features, MSTP, RSTP, multi-form ring redundancy, network control, monitor, security and notification. The JetNet 5010G also provides built-in watchdog timer, digital input and relay output to avoid undetected damage. With JetNet 5010G, you can fulfill the dream of having the perfect solution to construct your industrial Ethernet infrastructure.

3rd Gigabit Uplink for Flexible Network Planning

JetNet 5010G offers three Gigabit RJ-45/SFP combos which improve the performance dramatically compared to typical two Gigabit RJ-45/ SFP combos. Each combo comes with flexible connectivity, 100Mbps Single-Mode/Multi-Mode or 1000Mbps Single-Mode/Multi-Mode, as well as a copper connection. Now, end-users can achieve as many as 10 different combinations of port connections. Also, by selecting a suitable range of fiber transceivers, the JetNet5010G can fulfill your industrial applications at long distances.

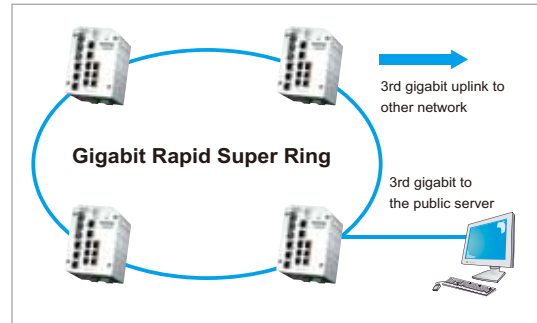

100 / 1000Mbps DDM Transceiver for High Quality Monitoring

The JetNet 5010G SFP socket supports 100Base- FX Single/Multi-Mode and 1000Base-SX/LX/LHX/XD Multi/Single-Mode transceiver. Moreover, it supports DDM (Digital Diagnostic Monitoring) type SFP transceivers allowing users to diagnose optical cable transmission problem through maintenance and debugging of the optical signal quality by DDM without the need of an extra optical cable analyzer as a result greatly saving time and system costs.



Comprehensive Redundant Solutions — Multiple Super Ring (MSR™)

The JetNet 5010G supports MSR™ (Multiple Super Ring); the new generation of RSR (Rapid Super Ring) technology. This new technology includes various new features for different network redundancy applications and structures. The JetNet 5010G allows aggregating up to 5 rings, including 4 Fast Ethernet and 1 Gigabit ring. With the MSR™ technology, a node can be configured to multiple rings with the failover time in as little as 5ms and ZERO-second of restore time. In addition, users can extend the ring topology by adding hundreds of JetNet 5010G to meet the network needs without compromising the speed of the network.

The MSR™ also facilitates the JetNet 5010G to connect with core management switch via standard Rapid Spanning Tree Protocol or through multiple paths or nodes to increase the reliability of the Rapid Dual Homing (RDH™) Technology. By integrating MSR™ and Link Aggregation Control Protocol (LACP), the JetNet 5010G can enhance the link availability and increase the link capacity. Two or more Fast Ethernet connections are bundled in order to increase the bandwidth and to create resilient and redundant links.

TrunkRing™

Symmetric TrunkRing™ Asymmetric TrunkRing™

TrunkRing™ is a new feature in MSR™ which merges the two technologies of RSR and link aggregation. It takes advantage of aggregation to enhance the link redundancy, while increasing the link speed. The ring will open only if all the aggregated links are broken. Link aggregation can be achieved by either, static trunk or LACP protocol. Not all the link sections in a TrunkRing™ need to be the same. Ring links can be either symmetric or asymmetric. Some are a single link, and the others are aggregated by links where the number of links in a trunk group can be different. Users can enhance the link redundancy at different locations in accordance to the need. The link with less speed is more likely to be used as the backup path for restoring the network to full play capacity.

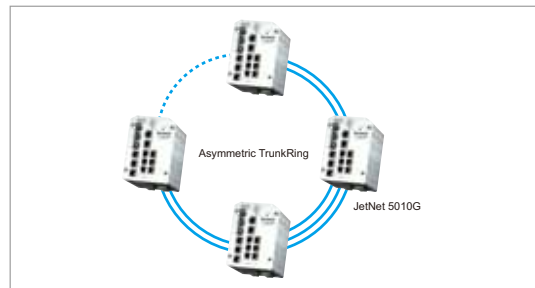
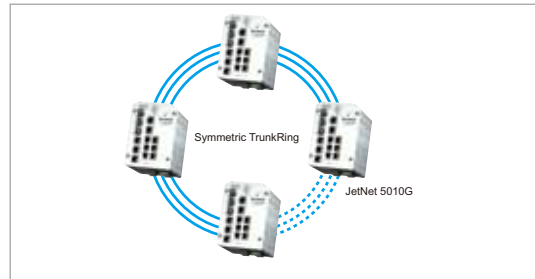

Industrial Intelligent NMS

Rackmount PoE Plus Switch

Industrial PoE Plus Switch

Industrial 12-24V PoE Switch

Industrial PoE Switch

Rackmount L3/L2 Switch

Gigabit Managed Switch

Managed Ethernet Switch

Entry-level Switch

Wireless Outdoor AP

Embedded PoE/Router Computer (LINUX)

Industrial Communication Computer (WIN/LINUX)

Ethernet/PoE/Serial Board

Ethernet I/O Server

Media Converter

Serial Device Server

SFP Module

Din Rail Power Supply

MultiRing™

MultiRing™ provides easier connectivity between two ring networks. The simplest example is to connect two rings by a single device. Depending on the number of ports, a device can even gather multiple rings together. As shown in the figure, MultiRing™ technology simply extends the network topology by linking multiple rings into a line or into multiple

directions. In addition to extensibility, MultiRing™ has great diversity of various ring technologies. With MultiRing™ enabled, a device can connect RSR™ rings, TrunkRing™ and a ring of Super Ring together. Which provides extensibility to new technologies while keeping the great backward compatibility.

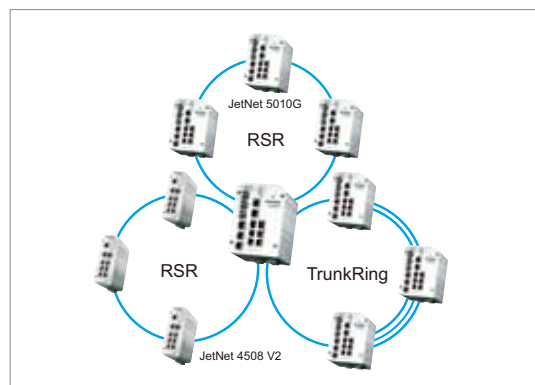
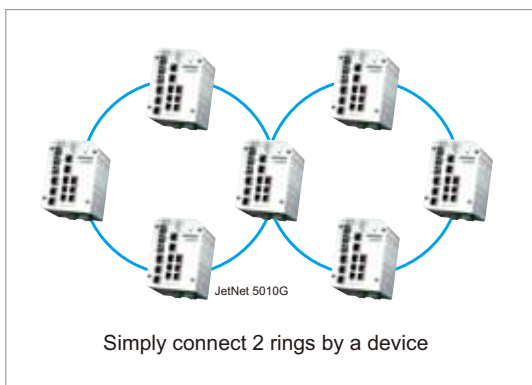

Rapid Dual Homing (RDH™) Technology

Rapid Dual Homing (RDH™) replaces DualHoming II and can be used for ring coupling. While keeping easy configuration and multiple redundancies, the failover time is much faster (less than 50 ms) and the restore time is ZERO (seamless restoration). Uplinks can be auto detected and gathered into groups. In each group, uplinks are sorted into Primary, Secondary,

and Standbys by their link speed. The uplink with the highest speed is more likely to be the active path for data transmission. Link aggregation is also integrated into RDH™. An uplink can be a link or several links aggregated as a trunk, which provides better redundancy and link capacity.

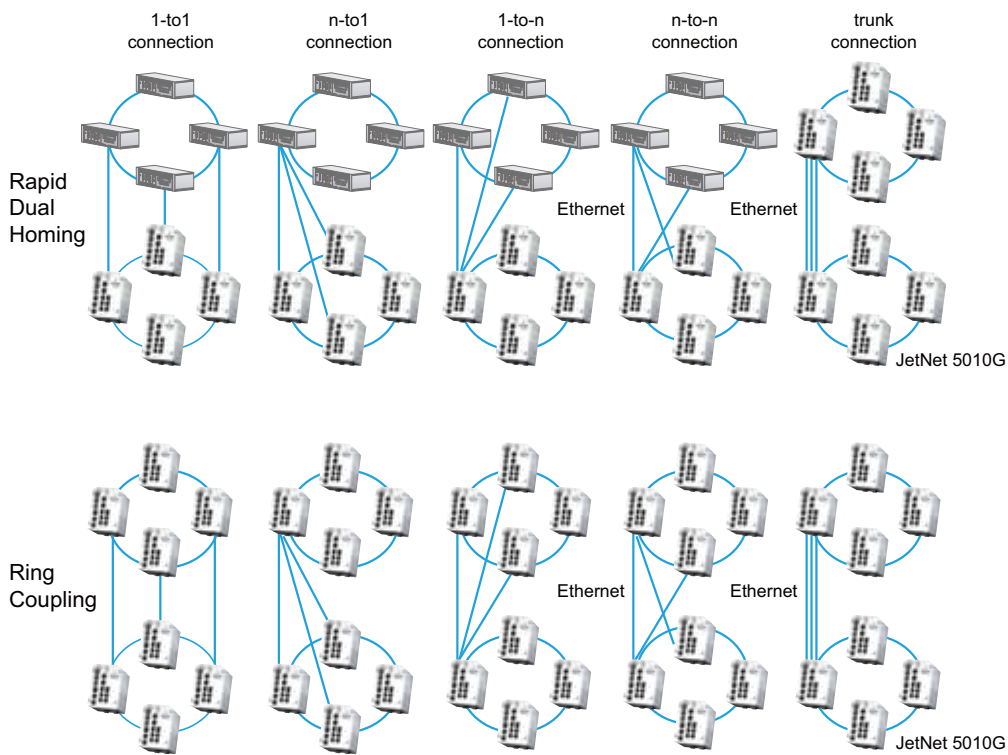

Various Network Control and Security Features

The JetNet 5010G provides various network control and security features. The Network Control feature allows users to optimize their industrial environment. The supported features include VLAN, IGMP Snooping, Quality of Service (QoS), Link Aggregation Control

Protocol (LACP), Rate Control. The security also helps users to avoid hackers' attack. The features included are, DHCP Server, IP and MAC Binding, 802.1x Access Control, SSH, IP Access Table and Port Security.

Port Security

Port Security is an enhanced security feature provided by JetNet 5010G. Port Security is also known as, “Port and MAC Binding”. Users can bind a specific MAC address to a specific port, add the MAC and Port binding entry/entries to the port security

table. After enabling this, only the PC with the available MAC address can access the network through the switch. The other PCs can't even pass the traffic through the port.

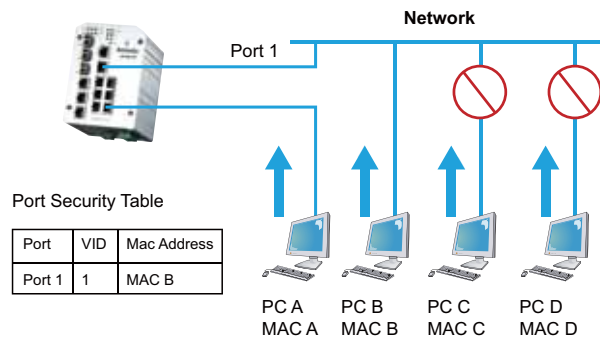

A Built-in Watchdog Timer

With a Built-In Watchdog Timer, the JetNet 5010G performs a warm boot (restarting the switch) automatically when the switch system locks up. It saves the effort of maintenance for keeping network alive if the switch can recover by itself.

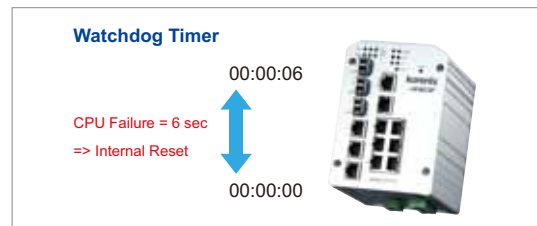

Robust Mechanical Design

Korenix JetNet 5010G's outstanding outlook is rock solid with strong functionality. Using aluminum extrusion case with IP 31 class protection, light weight, rigid shell and

excellent thermal conductivity units, it can operate reliably under harsh industrial environments.

Link Aggregation Control Protocol

Link Aggregation Control Protocol (LACP) allows you to group multiple Ethernet ports in parallel to increase the link bandwidth. The aggregated ports can be considered as one physical port, so that the bandwidth is higher than just one single Ethernet port. The member ports of the same trunk group can balance the loading and backup with each other. The LACP feature is usually used when you need higher bandwidth for the backbone network. This is an inexpensive way for users to transfer much more data. If the trunk port is also assigned as a ring port, it will become as a TrunkRing™, which means, that the bandwidth of ring path has increased with port trunk

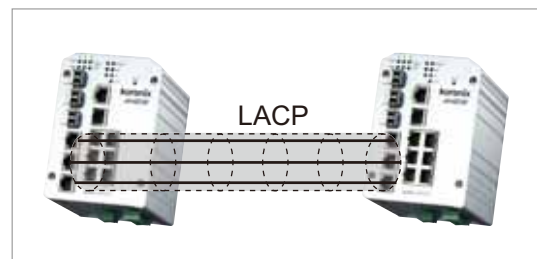

technology. Now, there is no recovery time when failures occur. The JetNet 5010G provides a simple and easy way to aggregate port bandwidth into Rapid Super Ring.

- Industrial Intelligent NMS
- Rackmount PoE Plus Switch
- Industrial PoE Plus Switch
- Industrial 12-24V PoE Switch
- Industrial PoE Switch
- Rackmount L3/L2 Switch
- Gigabit Managed Switch
- Managed Ethernet Switch
- Entry-level Switch
- Wireless Outdoor AP
- Embedded PoE/Router Computer (LINUX)
- Industrial Communication Computer (WIN/LINUX)
- Ethernet/PoE/ Serial Board
- Ethernet I/O Server
- Media Converter
- Serial Device Server
- SFP Module
- Din Rail Power Supply

LLDP and JetView Pro i²NMS for Auto Topology Visualization

The Link Layer Discovery Protocol (LLDP) was formally ratified as IEEE 802.1AB-2005. LLDP is the Layer 2 protocol that allows the network device/station to advertise connectivity & management information, the identity & major capabilities. If receives and establishes network management information on the local same network.

With SNMP, LLDP and JetView protocols supported, JetNet 5010G series can be easily discovered, their port and ring status can be displayed by JetView Pro, the Korenix designed Network Management System or other NMS, which supports SNMP and LLDP. The software can help administrators efficiently and effectively manage the industrial network.

In industrial environments, most vendors provide their own discovering protocols, window utility or other tools to manage their switches. The LLDP protocol fixes the interoperability among them. With LLDP supported, users can easily browse the network devices and establish the network management information schema about the stations.



Easy-to-Configure Network Management Features

The JetNet 5010G also provides users many advanced management features. It can be configured smartly by JetView, JetView Pro, Web browser, SNMP, Telnet and RS-232 console Command Line Interface (CLI).

It provides Failure notification by E-mail, SNMP Trap, System Log, Digital Input and Fault Relay. The JetNet 5010G also supports Built-In Watchdog Timer for system recovering when detecting CPU failure.

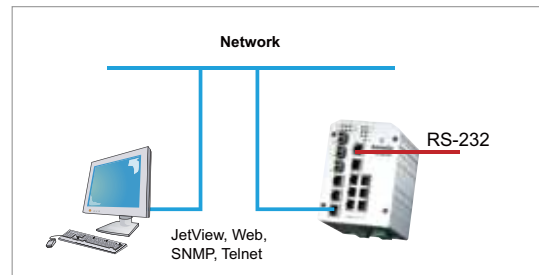

Modbus TCP/IP for Factory Automation Network Enhancement

The Modbus TCP/IP protocol is supported in JetNet 4508 V2 series for factory automation applications. It enables administrator to connect to data acquisition (SCADA) system and read the switch's operating information using its own Modbus TCP/IP master program for monitoring and maintaining switch's status. With the supported Modbus TCP/IP, the JetNet 4508 V2 series become an element of factory automation such as the Programmable Logic Controller (PLC), Distributed Control System (DCS), and allow users to monitor/maintain factory equipment on the HMI (Human Machine Interface) system, including production information and communication status. Therefore, user does not need to integrate multiple management platforms to

monitor factory equipment: with just a single JetNet 4508 V2 platform users can easily achieve enhanced monitoring and maintenance of the entire factory.

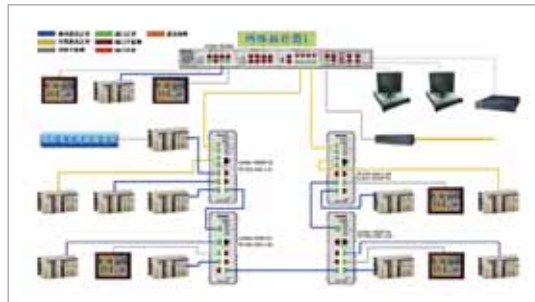

JetNet 5010G Appearance

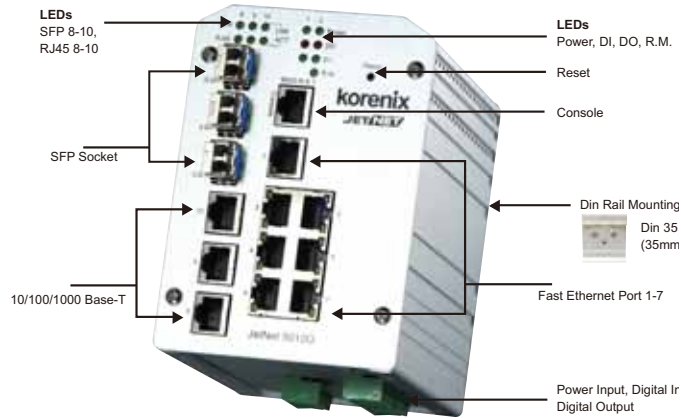

Industrial Intelligent NMS

Rackmount PoE Plus Switch

Industrial PoE Switch

Industrial 12-24V PoE Switch

Industrial PoE Switch

Rackmount L3/L2 Switch

Gigabit Managed Switch

Managed Ethernet Switch

Entry-level Switch

Wireless Outdoor AP

Embedded PoE/Router Computer (LINUX)

Industrial Communication Computer (WIN/LINUX)

Ethernet/PoE/ Serial Board

Ethernet I/O Server

Media Converter

Serial Device Server

SFP Module

Din Rail Power Supply

Dimension (Unit = mm)

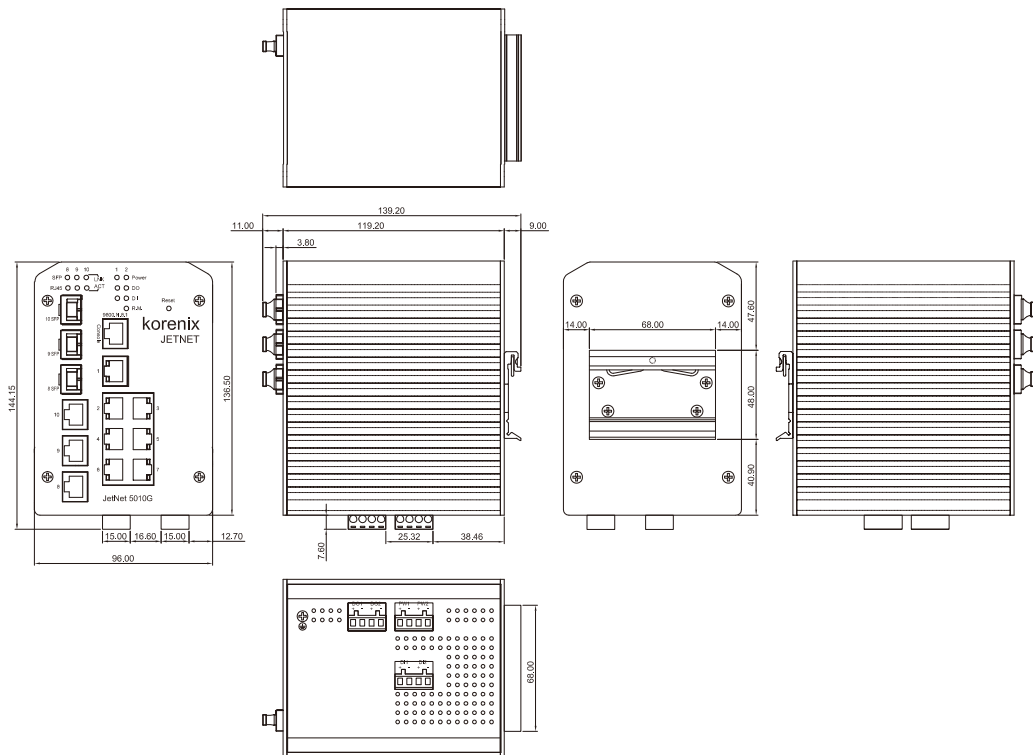

Specification

Technology

Standard:

IEEE 802.3 10Base-T Ethernet
 IEEE 802.3u 100Base-TX Fast Ethernet
 IEEE 802.3ab 1000Base-T
 IEEE 802.3z Gigabit Ethernet Fiber
 IEEE 802.3x Flow Control and Back-pressure
 IEEE 802.1p Class of Service
 IEEE 802.1Q VLAN and GVRP
 IEEE 802.1QinQ
 IEEE 802.1s Multiple Spanning Tree Protocol(MSTP)
 IEEE 802.1D-2004 Rapid Spanning Tree Protocol (RSTP)
 IEEE802.3ad LACP
 IEEE802.1X Port_based Network Access Control
 IEEE802.1AB Link Layer Discovery Protocol
 ModBus TCP/IP

Performance

Switch Technology:

Store and Forward Technology with 32Gbps Switch Fabric.

System Throughput: 14,880pps for 10M Ethernet, 148,800pps for 100M Fast Ethernet, 1,488,100 for Gigabit Ethernet

Transfer packet size: 64 bytes to 1522 bytes (with VLAN Tag)

MAC Address: 8K MAC

Packet Buffer: 1Mbits

Relay Alarm: Dry Relay output with 1A@24V ability

Management

Configuration: Cisco-Like CLI, JetView, Web browser with multiple languages, HTTPS, SSH; TFTP/Web Update for firmware and configuration backup/restore, DHCP Client, Warm reboot, Reset to default, Admin password, Port Speed/Duplex control, status, statistic, MAC address table display, Static MAC, Aging time

SNMP v1, v2c, v3, Traps and RMON1.

SNMP MIB: MIB-II, Bridge MIB, VLAN MIB, SNMP MIB, RMON and Private MIB

Port Trunk: Up to 5 Static Trunk and IEEE802.3ad LACP

VLAN: IEEE802.1Q VLAN, GVRP. Up to 64 VLAN groups

Private VLAN: Direct client ports in isolated/community VLAN to promiscuous port in primary VLAN

QinQ: Double VLAN Tag in an Ethernet frame

Quality of Service: Four priority queues per port, IEEE802.1p COS and Layer 3 TOS/DiffServ

IGMP Snooping: IGMP Snooping V1/V2/V3 for multicast filtering and IGMP Query V1/V2

Rate Control: Ingress filtering for Broadcast, Multicast, Unknown DA or All packets, and Egress filtering for All packets

NTP: Network Time Protocol to synchronize time from Internet or local PC

Embedded Watchdog: Embedded hardware watchdog timer to auto reset system when switch system failure

Port Mirroring: Online traffic monitoring on multiple selected ports

Port Security: Assign authorized MAC to specific port

IP Security: IP security to prevent unauthorized access

802.1x: Port_based Network Access Control

Radius: Login by Radius account/password, Key for Radius Server Authentication

DHCP Server: Up to 255 IP address, support IP and MAC binding

DHCP Option 82: Relay the DHCP request

E-mail Warning: Automatic warning by pre-defined events

System Log: Supports both Local mode and Server mode

Modbus TCP/IP: Supports open protocol- Modbus TCP/IP with function code group 4 for factory automation application.

Network Redundancy

Multiple Spanning Tree Protocol: IEEE802.1s MSTP,

each MSTP instance can include one or more VLANs

Rapid Spanning Tree Protocol: IEEE802.1D-2004 Rapid Spanning Tree Protocol. Compatible with Legacy STP and IEEE802.1w.

Rapid Super Ring(RSR): 2nd generation Korenix Ring Redundancy Technology. Failure recovery within 5ms.

Rapid Dual Homing (RDH™): Multiple uplink paths to upper switches

MultiRing™: Couple or multiple Rapid Super Rings

Legacy Super Ring: Backward compatible in client mode

Interface

Number of Ports: 10/100TX: 7 x RJ-45, Auto MDI/MDI-X, Auto Negotiation

10/100/1000TX: 3 x RJ-45, combo with SFP

Gigabit Fiber/100Base-FX: 3 x SFP with Hot Swappable

Cables:

10Base-T: 2-pair UTP/STP Cat. 3, 4, 5 cable (100m)

100 Base-TX: 2/4-pair UTP/STP Cat. 5 cable (100m)

1000 Base-T: 4-pair UTP/STP Cat. 5 cable (100m)

Diagnostic LED:

10/100 RJ-45: Link/Activity(Green), Full duplex/Collision (Yellow)

Gigabit Copper/SFP: Link/Activity(Green)

Unit: Power(Green), Digital Out(Red), Digital Input(Green), R.M.(Green)

RS232 Console: RJ-45 Connector, Pin3: TxD, Pin6: RxD, Pin5:GND

Power: 2 sets of power Inputs

Digital Input: 2 sets of Digital Input

Logic Low (0): 0-10VDC/Logic High(1): 11-30VDC

Alarm: 2 sets of Relay outputs for pre-defined events

Reset: Reset button is provided to restore default settings

Power Requirements

System Power: 12~48V/-12~-48VDC with Reverse Polarity Protection

Power Consumption: 11.5 Watts @ DC 48V

Mechanical

Installation: DIN-Rail mount or Wall Mount

Case: IP31 protection, aluminum metal case

Dimension: 137mm(H) x 96mm (W) x 119mm (D)

Weight: 0.915kg with package

Environmental

Operating Temperature: -25 ~70°C (JetNet 5010G),
 -40 ~70°C (JetNet 5010G-w),
Operating Humidity: 0% ~ 95% (non-condensing)
Storage Temperature: -40 ~ 85°C
Hi-Pot: 1.2KV for power
 1KV for ports

Regulatory Approvals

EMI: EN55022 CLASS A, EN61000-3-2,
 EN61000-3-3, EN61000-6-4

EMS: EN55024, EN61000-6-2, IEC 61000-4-2,
 IEC 61000-4-3, IEC 61000-4-4, IEC 61000-4-5,
 IEC 61000-4-6, IEC 61000-4-8, IEC 61000-6-2

Safety: UL 508

Shock: IEC60068-2-27

Vibration: IEC60068-2-6

Free Fall: IEC60068-2-32

MTBF:

249,683 Hours, MIL-HDBK-217F GB standard
 (JetNet 5010G)

383,380 Hours, MIL-HDBK-217F GB standard
 (JetNet 5010G-w)

Warranty: 5 years

Industrial
 Intelligent
 NMS

Rackmount
 PoE Plus
 Switch

Industrial
 PoE Plus
 Switch

Industrial
 12-24V
 PoE Switch

Industrial
 PoE Switch

Rackmount
 L3/L2 Switch

**Gigabit
 Managed
 Switch**

Managed
 Ethernet
 Switch

Entry-level
 Switch

Wireless
 Outdoor AP

Embedded
 PoE/Router
 Computer
 (LINUX)

Industrial
 Communication
 Computer
 (WIN/LINUX)

Ethernet/PoE/
 Serial Board

Ethernet
 I/O Server

Media
 Converter

Serial Device
 Server

SFP Module

Din Rail
 Power Supply

Ordering Information

JetNet 5010G Industrial 7+3G Gigabit Managed Ethernet Switch, -25~70°C operating temperature

JetNet 5010G-w Industrial 7+3G Gigabit Managed Ethernet Switch, -40~70°C operating temperature

Includes:

- JetNet 5010G / 5010G-w (without SFP transceiver)
- Wall mounting plate
- Quick Installation Guide
- Documentation CD-ROM
- Console cable

Optional Accessories

100Base-FX SFP Transceiver

100Base-FX BIDI/WDM SFP Transceiver

100Base-FX SFP Transceiver with DDM

100Base-FX BIDI/WDM SFP Transceiver with DDM

Gigabit SFP Transceiver

Gigabit SFP Transceiver with DDM

Gigabit BIDI/WDM SFP Transceiver

Gigabit BIDI/WDM SFP Transceiver with DDM