

Panel Mounted LVDS&DVI-D Inputs Supported  
FLAT PANEL DISPLAY 70 Series

Panel Mounted 71



Model	Screen size	Number of pixels	Number of colors
FPD-S71VT-DC1	6.5 inches	640 x 480 dots	262,144 colors
FPD-L71ST-DC1	12.1 inches	800 x 600 dots	262,144 colors
FPD-H71XT-DC1	15.0 inches	1024 x 768 dots	16,777,216 colors

\* Specifications, color and design of the products are subject to change without notice.

Features

**LVDS and DVI-D inputs supported panel mount TFT LCD display**

LVDS and DVI-D inputs, that are less affected by the interference of noise, are supported for host computer connection. Because of the digital signal input, up to 5 m of cable length is available. The video signal and touch panel signal can be connected with one cable depending on the host PC to be connected.

Full-bright, wide-angle-of-visibility type of liquid crystals capable of displaying up to 16,777,216 colors on the 15 inches and 262,144 colors on the 12.1/6.5 inches by adopting the lightweight aluminum-made front.

**Touch panel enables keyboard-less operation.**

These products have analog touch panel enabling mouse emulation using driver software. Touch panel is available via RS-232C (Built-in video cable) or USB connection.

**The panel attachment size compatible with IPC-DT60(Panel mounted 61) series**

Because its panel attachment is compatible with the predecessor IPC-DT60(Panel mounted 61) series, they are transposable.

**Front side in IP65-rated dustproof/drip-proof structure**

Front side in IP65-rated dustproof/drip-proof structure

**AC adapter, stand and connection cable is available as option.**

An optional AC adapter (IPC-ACAP12-02), stand (IPC-SND-03) and connection cable is available to run the display from the AC power supply, to use as a desktop display and for connection to the host computer.

\* For more details on host computer or option of this product, contact your retailer.

Specifications

Function Specifications

Item	Specification		
	FPD-S71VT-DC1	FPD-L71ST-DC1	FPD-H71XT-DC1
Screen			
Assembly type	Panel mounted, desktop *1		
Screen size	6.5 inches	12.1 inches	15.0 inches
Number of pixels	640 x 480 dots	800 x 600 dots	1024 x 768 dots
Display type	TFT Color LCD		
Number of colors	262,144 colors	262,144 colors	16,777,216 colors *4
Brightness control	Adjustment using the front switch or software control from the host computer		
Backlight control	Can be turned on or off by a front switch or via software control from the host computer.		
Display interface	LVDS input (26 pin half pitch connector) DVI-D input (24 pin DVI (Female) connector)		
Input signal specification	LVDS input	26 pin half pitch connector *2	
	DVI-D input	Digital RGB (complies with TMDS) *2	
Cable length which recommends	5m or less		
Touch panel			
Resolution	4096 x 4096		
Detection method	Resistive-layer analog method		
Touch life expectancy	One million repeated touches (as tested by mechanical touching under 300g of force at a rate of two presses per second)		
Touch panel interface	Connect to the host computer using either USB *3 or RS-232C. RS-232C : built-in LVDS/DVI Connector USB: USB1.1-compliant, TypeB Connector		
Touch panel driver (option)	For Windows : IPC-SLIB-01		

\*1 Optional desk stand IPC-SND-03 allowing desktop installation

\*2 Using a cable longer than 5 m may reduce the image quality. The cable should be as short as possible as degradation. the image quality may result even when the cable is 5 m or shorter depending on the type of host computer or cable.

\*3 The touch panel USB interface is only supported on Windows XP/2000/98SE.

\*4 It is 262,144 when connecting the LVDS.

Power Supply Specifications

Item	Specification		
	FPD-S71VT-DC1	FPD-L71ST-DC1	FPD-H71XT-DC1
Power supply input part			
Power supply connector	4-pin connector for +12 - 24VDC power supply		
AC adapter jack	Corresponding to +12 (±5%) VDC output AC adapter		
Input power supply voltage	+12V-24VDC±5%		
Consumption current *1	0.6A (Max.)	1.4A (Max.)	1.6A (Max.)
Consumption current (power save mode) *1	0.4A (Max.)		

\*1 When +12VDC is input.

**General Specifications**

Item	Specification		
	FPD-S71VT-DC1	FPD-L71ST-DC1	FPD-H71XT-DC1
<b>Environment</b>			
Operating temperature *1	0 - 50°C (0 - 40°C when using an AC adapter)		
Storage temperature	-10 - 60°C		
Operating humidity *2	10 - 90%RH (No condensation) 10 - 85%RH (No condensation) (When using the AC adapter)		
Floating dust particles	Not to be excessive		
Corrosive gas	None		
Noise resistance	Line noise	AC line: 2 kV *3, Signal line: 1 kV (IEC1000-4-4Level3, EN61000-4-4Level3)	
	Electrostatic withstanding voltages	Contact : 4 kV (IEC1000-4-2Level2, EN61000-4-2Level2) Airborne : 8 kV (IEC1000-4-2Level3, EN61000-4-2Level3)	
Vibration resistance	10 - 57 Hz/Single-side amplitude or 0.075 mm 57 - 150 Hz/1.0 G in the X/Y/Z directions for 40 minutes each (Conforming to JIS C0040 and IEC68-2-6)		
Shock resistance	10 G in the X/Y/Z directions for 11 ms; Half-sine wave (Conforming to JIS C0041 and IEC68-2-27)		
<b>Structure</b>			
Physical dimension (mm)	210(W) x 40(D) x 166(H)	316(W) x 46.5(D) x 256(H)	373(W) x 46(D) x 304(H)
Panel cut dimensions (mm)	199.0(W) x 155.0(H)	303.0(W) x 243.0(H)	358.0(W) x 289.0(H)
Mountable panel thickness	1.6mm - 7mm		
Weight	1.3kg	2.8kg	4.1kg
Waterproofing and dust-proofing	Front part conforming to IP65		

\*1 In the installed angle which is recommended  
\*2 Wet-bulb temperature 38°C or lower.  
\*3 When using the optional AC adapter IPC-ACAP12-02.

**Optical Display Specifications**

Item	Condition	Specifications (25°C Typ. Value)		
		FPD-S71VT-DC1	FPD-L71ST-DC1	FPD-H71XT-DC1
Visual angle (vertical)	CR≥10 Display in monochrome	φ=180°	50deg	50deg
		φ=0°	70deg	70deg
Visual angle (horizontal)	φ=+90° φ=-90°	70deg	70deg	75deg
		70deg	70deg	75deg
Surface brightness (at center)	Display in white	550cd/m <sup>2</sup>	350cd/m <sup>2</sup>	250cd/m <sup>2</sup>

\*1 Surface brightness is a numerical value in a display simple substance. The brightness that let the touch panel pass serves as about 77% of the above-mentioned numerical value.  
\*2 CR = Contrast ratio

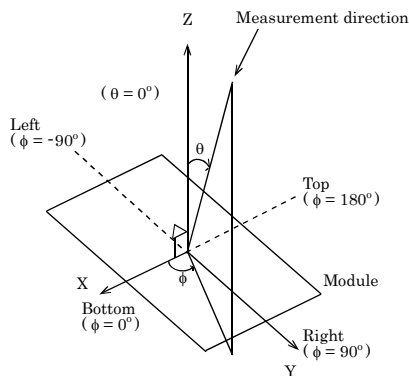

**CAUTION**

The above optical specification data shows optical characteristics of the liquid crystal in the display; the data does not represent the actual view on the display or its viewing angles.

**Options**

**Screen protective sheets**

- IPC-CV6 :6.5-inch [FPD-S71VT-DC1] screen protective sheets (10 sheets)
- IPC-CV12 :12.1-inch [FPD-L71ST-DC1] screen protective sheets (10 sheets)
- IPC-CV15 :15-inch [FPD-H71XT-DC1] screen protective sheets (10 sheets)

**Display cable only for DVI-D**

- IPC-DVI/D-020 :DVI-D cable (2m)
- IPC-DVI/D-050 :DVI-D cable (5m)

**Display cable only for LVDS**

- FPD-26M26M-005 :LVDS cable (0.5m)
- FPD-26M26M-020 :LVDS cable (2m)
- FPD-26M26M-050 :LVDS cable (5m)

**Conversion cable for SBC \*1**

- FPD-20F26F :LVDS connector conversion cable (20-pin header connector)
- FPD-30F26F :LVDS connector conversion cable (30-pin header connector)

\*1 LVDS cable FPD-26M26M-005, FPD-26M26M-020 or FPD-26M26M-050 is required separately.

**Driver**

- IPC-SLIB-01 :Driver & Utility Soft Set (CD-ROM version) \*2

\*2 You can download the driver from the CONTEC Web site (free of charge)

**Others**

- IPC-ACAP12-02 :AC ADAPTER (DC12V)  
Input :Voltage is 90 - 264VAC, current is 1.3A or less  
(when the input voltage is 100VAC)  
Output :Voltage is 12VDC, current is 4A.
- IPC-SND-03 :Desk stand

**Recommendation Cable (Maker: SANWA SUPPLY INC.)**

- KU20-2H :USB cable for touch panel (2m)
- KU20-5H :USB cable for touch panel (5m)

**Packing List**

Name	FPD-S71VT-DC1	FPD-L71ST-DC1	FPD-H71XT-DC1
	Pcs.	Pcs.	Pcs.
Flat panel display	1	1	1
Three-point sems screws (M3 x 6)	1	1	1
Power supply connector complete set (Contact...4, housing...1)	1 set	1 set	1 set
Clamp for preventing cables from being disconnected	2	1	3
The attachment fittings	4	6	8
AC adapter jack fixed clamp	1	1	1
IPC Precaution List	1	1	1
Waterproof packing Precaution List	1	1	1
Product guide	1	1	1
EU/FCC Declaration of Conformity	1	1	1

(Note) The manual of this product is being offered as PDF file on the CONTEC's Web site. Each cable for this product is not bundled. Purchase it separately.

**Life expectancy of consumable components**

- (1) Backlight --- Display brightness decreases over time with use. The operating life of the backlight (brightness reduced to 50% of original) is 50,000 hours for all models. (Assuming continuous operation at 25 degrees centigrade.)
- (2) Touch panel --- The operating lifetime of the touch panel is at least 1 million touches (as tested by mechanical touching under 300g of force at a rate of two presses per second).

\* CONTEC accepts your request for replacing each consumable in these products as a request for repair (at an additional cost). Contact your local retailer or CONTEC sales office.

## Physical Dimensions

### FPD-S71VT-DC1

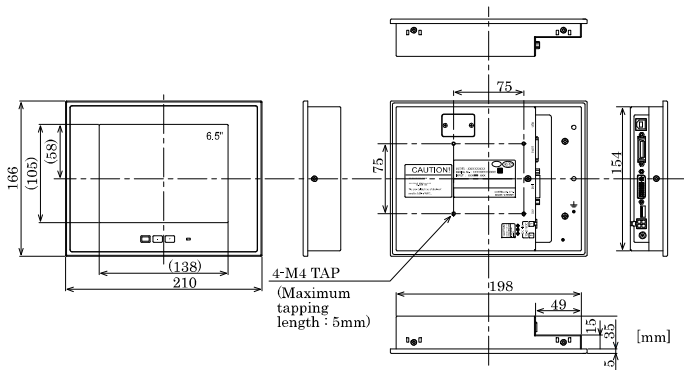

### FPD-L71ST-DC1

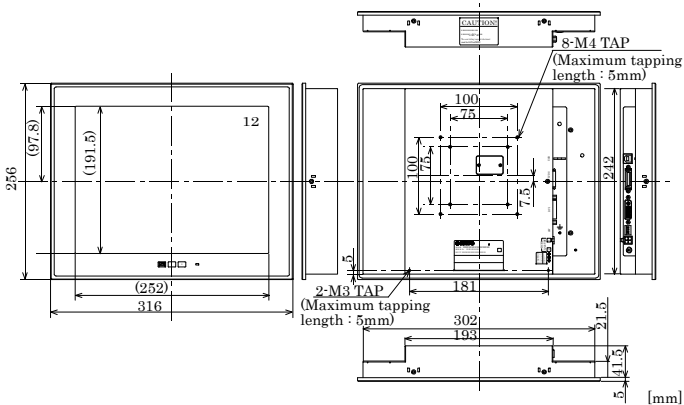

### FPD-H71XT-DC1

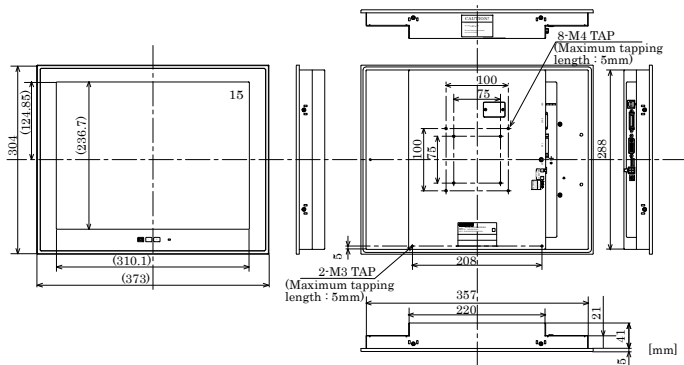

## Part Names

### Part Names

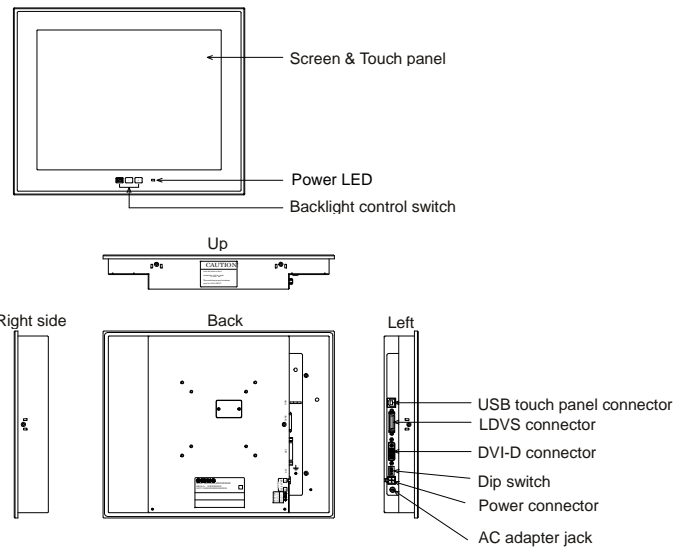

### Backlight control switch

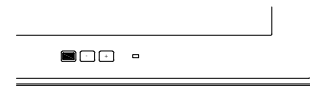

## Setting the Display

### Installation Requirements

#### Distances between this product and Its Vicinity

To maintain the ambient temperature within the installation environment requirement range, provide a gap of 50mm or more between the main unit and any adjacent equipment.

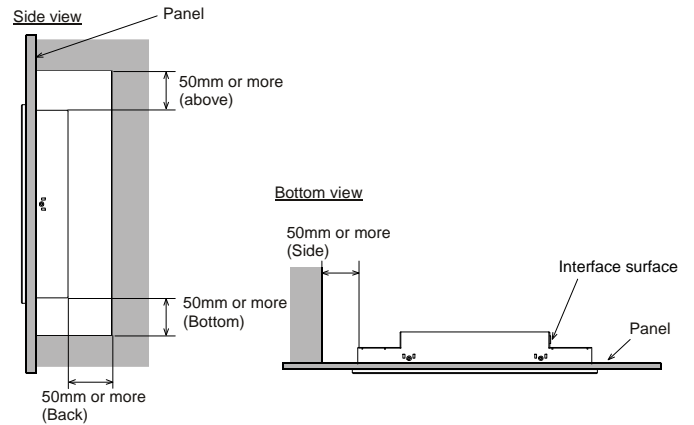

**Installed angle which is recommended**

Installed angle of this product which is recommended is 0 - 45°. Except for that, the temperature specification of this product might not be filled.

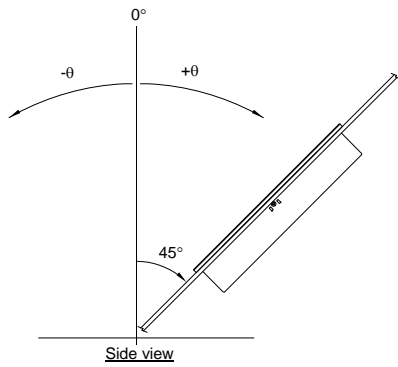

**Panel Cut**

Cut the display mount panel in the following dimensions. The four corners of the solid-line rectangle define the panel cut dimensions.

**FPD-S71VT-DC1 [6.5 inches] Panel Cut Dimensions and hole position for stud**

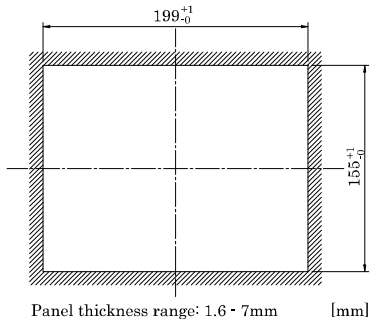

**FPD-L71ST-DC1 [12.1 inches] Panel Cut Dimensions and hole position for stud**

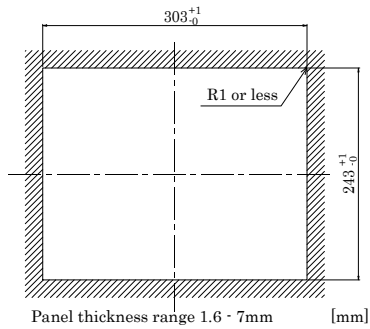

**FPD-H71XT-DC1 [15 inches] Panel Cut Dimensions and hole position for stud**

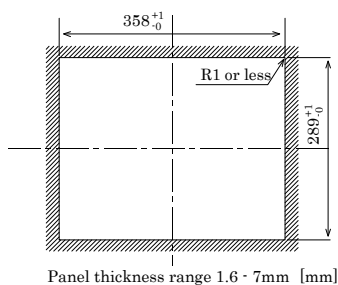

**Touch Panel**

This equipment has a touch panel that enables keyboard-less, mouse-less operations by communication with the host computer using the RS-232C cable.

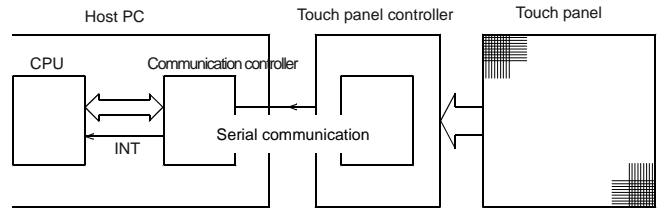
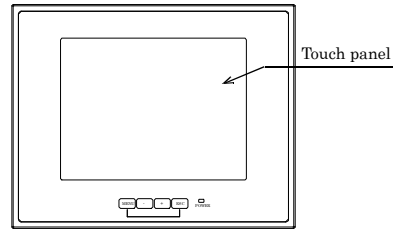

Data input at the touch panel is processed by the touch panel controller and passed to the host PC via the serial port on the CPU in the controller.

Before the touch panel can be used, touch panel driver software must be installed. Note that the driver software is not bundled with this product. Purchase the one separately or download it from the CONTEC's web site.

For further details, refer to the READ\_ME file for each driver.

< Option touch panel driver >

Windows XP/2000/NT 4.0/98SE/95OSR2 : IPC-SLIB-01