

Isolated Digital Output board
for PCI Express

DO-32L-PE



* Specifications, color and design of the products are subject to change without notice.

Features

Opto-coupler isolated open-collector output (current sink type)

This product has the opto-coupler isolated open-collector output 32ch (supporting current sink output) whose response speed is 200μsec. Common terminal provided per 16ch, capable of supporting a different external power supply Supporting driver voltages of 12 - 24 VDC for output

Opto-coupler bus isolation

As the PCI Express bus (PC) is isolated from the output interfaces by opto-couplers, this product has excellent noise performance.

Windows/Linux compatible driver libraries are attached.

Using the attached driver library API-PAC(W32) makes it possible to create applications of Windows/Linux. In addition, a diagnostic program by which the operations of hardware can be checked is provided.

Output circuits include zener diodes for surge voltage protection and poly-switches for overcurrent protection.

Zener diodes are connected to the output circuits to protect against surge voltages. Similarly, polyswitches are fitted to each group of 8ch outputs for over-current protection. The output rating is max. 35VDC, 100mA per ch.

Functions and connectors are compatible with PCI compatible board PO-32L(PCI)H.

The functions same with PCI compatible board PO-32L(PCI)H are provided.

In addition, as there is compatibility in terms of connector shape and pin assignments, it is easy to migrate from the existing system.

LabVIEW is supported by a plug-in of dedicated library VI-DAQ.

Using the dedicated library VI-DAQ makes it possible to create each application for LabVIEW.

This product is a PCI Express bus-compliant interface board that extends the digital signal output functions of a PC. 12 - 24VDC opto-coupler isolated type with open-collector output 32ch. Equipped with the output transistor protection circuit (surge voltage protection and overcurrent protection). Windows/Linux driver is bundled with this product. Possible to be used as a data recording device for LabVIEW, with dedicated libraries.

Specification

Item	Specification	
Output		
Output format	Opto-coupler isolated open collector output (current sink type) (Negative logic *1)	
Number of output signal channels	32ch (1 common in 16ch)	
Output rating	Output voltage	35VDC (Max.)
	Output current	100mA (par channel) (Max.)
Residual voltage with output on	0.5V or less (Output current≤50mA), 1.0V or less (Output current≤100mA)	
Surge protector	Zener diode RD47FM(NEC) or equivalent to it	
Response time	Within 200μsec	
Common		
Built-in power	None	
Allowable distance of signal extension	Approx. 50m (depending on wiring environment)	
I/O address	Any 32-byte boundary	
Interruption level	None	
Max. board count for connection	16 boards including the master board	
Isolated Power	1000Vrms	
External circuit power supply	12 - 24VDC (±10%)	
Power consumption	3.3VDC 450mA	
Operating condition	0 - 50°C, 10 - 90%RH (No condensation)	
Bus specification	PCI Express Base Specification Rev. 1.0a x1	
Dimension (mm)	121.69(L) x 110.18(H)	
Connector	37 pin D-SUB connector [F (female) type] DCLC-J37SAF-20L9E [mfd by JAE] or equivalent to it	
Weight	130g	

*1 Data "0" and "1" correspond to the High and Low levels, respectively.

Board Dimensions

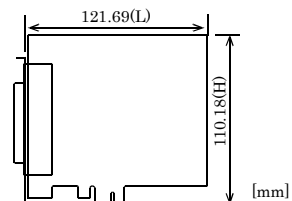

The standard outside dimension (L) is the distance from the end of the board to the outer surface of the slot cover.

Support Software

Windows version of digital I/O driver

API-DIO(WDM)/API-DIO(98/PC)

[Stored on the bundled CD-ROM driver library API-PAC(W32)]

The API-DIO(98/PC) is the Windows version driver library software that provides products in the form of Win32 API functions (DLL). Various sample programs such as Visual Basic and Visual C++, etc and diagnostic program useful for checking operation is provided.

< Operating environment >

OS Windows Vista, Windows XP, Server 2003, 2000

Adaptation language Visual Basic, Visual C++, Visual C#, Delphi, C++ Builder

You can download the updated version from the CONTEC's Web site (<http://www.contec.com/apipac/>). For more details on the supported OS, applicable language and new information, please visit the CONTEC's Web site.

Linux version of digital I/O driver API-DIO(LNX)

[Stored on the bundled CD-ROM driver library API-PAC(W32)]

The API-DIO(LNX) is the Linux version driver software which provides device drivers (modules) by shared library and kernel version. Various sample programs of gcc are provided.

< Operating environment >

OS RedHatLinux, TurboLinux
(For details on supported distributions, refer to Help available after installation.)

Adaptation language gcc

You can download the updated version from the CONTEC's Web site (<http://www.contec.com/apipac/>). For more details on the supported OS, applicable language and new information, please visit the CONTEC's Web site.

Data acquisition VI library for LabVIEW VI-DAQ (Available for downloading (free of charge) from the CONTEC web site.)

This is a VI library to use in National Instruments LabVIEW. VI-DAQ is created with a function form similar to that of LabVIEW's Data Acquisition VI, allowing you to use various devices without complicated settings. See <http://www.contec.com/vidaq/> for details and download of VI-DAQ.

Cable & Connector

Cable (Option)

Flat Cable with Two 37-pin D- SUB Connectors
: PCB37P-1.5 (1.5m)
: PCB37P-3 (3m)
: PCB37P-5 (5m)

Shielded Cable with Two 37-pin D- SUB Connectors
: PCB37PS-0.5P (0.5m)
: PCB37PS-1.5P (1.5m)
: PCB37PS-3P (3m)
: PCB37PS-5P (5m)

Flat Cable with One 37-pin D- SUB Connector
: PCA37P-1.5 (1.5m)
: PCA37P-3 (3m)
: PCA37P-5 (5m)

Shielded Cable with One 37-pin D- SUB Connector
: PCA37PS-0.5P (0.5m)
: PCA37PS-1.5P (1.5m)
: PCA37PS-3P (3m)
: PCA37PS-5P (5m)

Connector (Option)

37-pin D-SUB Male Connector Set (5 Pieces)

: CN5-D37M

Accessories

Accessories (Option)

Screw Terminal (M3 x 37P) : EPD-37A *1
Screw Terminal (M3.5 x 37P) : EPD-37 *1
General Purpose Terminal : DTP-3A *1
Screw Terminal : DTP-4A *1
Signal Monitor for Digital I/O : CM-32(PC)E *1

*1 A PCB37P or PCB37PS optional cable is required separately.

* Check the CONTEC's Web site for more information on these options.

Packing List

Board [DO-32L-PE] ...1
First step guide ... 1
CD-ROM *1 [API-PAC(W32)] ...1

*1 The CD-ROM contains the driver software and User's Guide.

Block Diagram

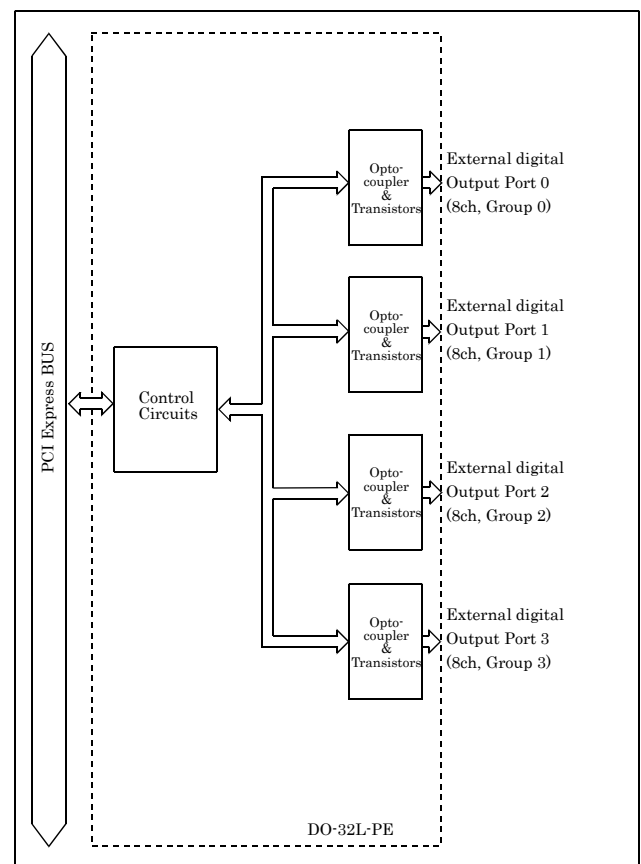

How to connect the connectors

Connector shape

The on-board interface connector (CN1) is used when connecting this product and the external devices.

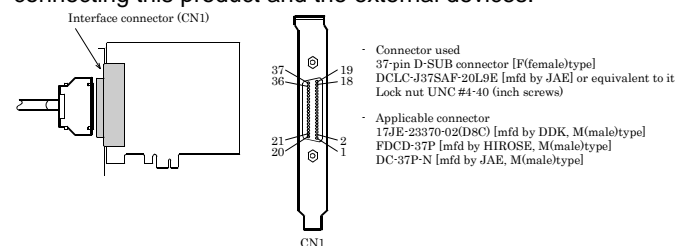

* Please refer to page 2 for more information on the supported cable and accessories.

Connector Pin Assignment

Pin Assignments of Interface Connector (CN1)

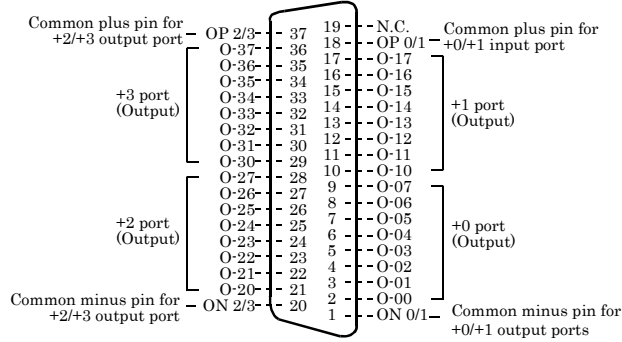

O-00 - O-37	32 output signal pins. Connect these pins to the input signal pins of the external device.
OP 0/1 - OP 2/3	Connect the positive side of the external power supply. These pins are common to 16 output signal pins.
ON 0/1 - ON 2/3	Connect the negative side of the external power supply. These pins are common to 16 output signal pins.
N.C.	This pin is left unconnected.

Connecting Output Signals

Connect the output signals to a current-driven controlled device such as a relay or LED.

The connection requires an external power supply to feed currents.

The board controls turning on/off the current-driven controlled device using a digital value.

Output Circuit

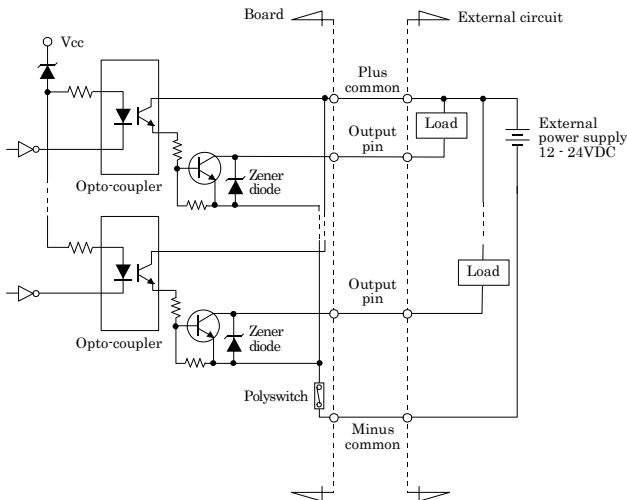

* O-xx represents the output pin.

The output circuits of interface blocks of this product is illustrated in the image above. The signal output section is an opto-coupler isolated, open-collector output (current sink type). Driving the output section requires an external power supply.

The rated output current per channel is 100mA at maximum.

The output section can also be connected to a TTL level input as it uses a low-saturated transistor for output. The residual voltage (low-level voltage) between the collector and emitter with the output on is 0.5V or less at an output current within 50mA or at most 1.0V at an output current within 100mA.

A zener diode is connected to the output transistor for protection from surge voltages. A PolySwitch-based overcurrent protector is provided for every 8 output transistors. When the overcurrent protector works, the output section of the board is temporarily disabled. If this is the case, turn off the power to the PC and the external power supply and wait for a few minutes, then turn them on back.

CAUTION

When the PC is turned on, all output are reset to OFF.

Connection to the LED

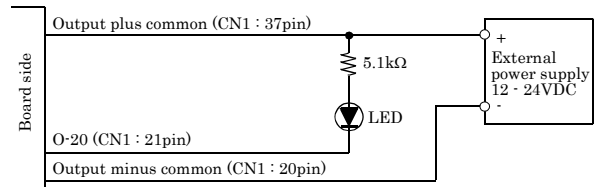

When "1" is output to a relevant bit, the corresponding LED comes on.
When "0" is output to the bit, in contrast, the LED goes out.

Example of Connection to TTL Level Input

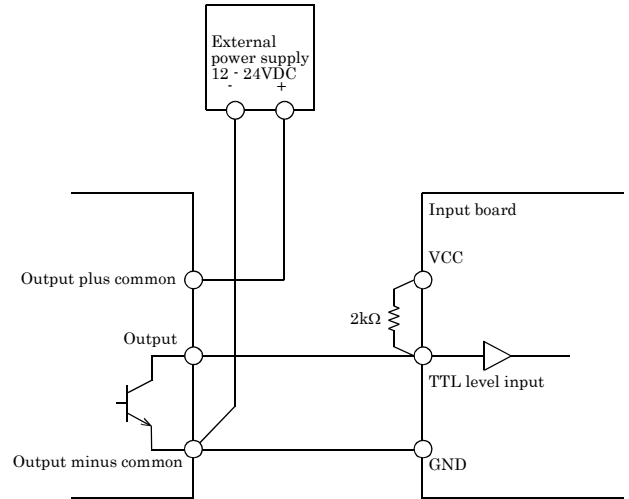

Connecting the Sink Type Output and Sink Output Support Input

The following example shows a connection between a sink type output (output board) and a sink output support input (input board). Refer to this connection example when you connect such boards to each other.

